

# Model T Parts

1909  
to  
1927



Helpful Information

## Specifications

<b>Engine</b>	4 Cylinder .....	Stroke 4"
	Bore 3-3/4" .....	Horsepower 20
	Firing Order .....	1-2-4-3
<b>Crankshaft Journals</b>	.....	1.248" Diameter
<b>Cam Bearing Clearance</b>	.....	.003 Side Play
<b>Valve Push Rod to Stem Clearance</b>	.....	.022 to .032
<b>Valve Spring Tension</b>	.....	24-28 Pounds
<b>Oil Capacity</b>	.....	4 quarts
<b>Coil Points Gap</b>	.....	.030"
<b>Spark Plugs Gap</b>	.....	.032"
<b>Crankshaft End Play</b>	.....	.015"

### *Motor Numbers for Reference Only:*

<b>1912</b> .....	698,877-157,205 .....	1920 .....	3,277,885-4,233,350
<b>1913</b> .....	169,452-370,147 .....	1921 .....	4,233,351-5,233,135
<b>1914</b> .....	370,148-570,790 .....	1922 .....	5,223,136-6,334,196
<b>1915</b> .....	570,791-885,500 .....	1923 .....	6,334,197-8,122,674
<b>1916</b> .....	885,501-1,362,200 .....	1924 .....	8,122,675-10,266,471
<b>1917</b> .....	1,362,201-2,113,500 .....	1925 .....	10,266,472-12,222,528
<b>1918</b> .....	2,113,501-2,756,251 .....	1926 .....	12,222,529-14,049,029
<b>1919</b> .....	2,756,252-3,277,851 .....	1927 .....	14,049,030-15,007,033

We have many USED Model 'T' Parts...ask us.

# Model T Parts

Part #	Description	Reqd.	Years	Price
<b>Rear Axle</b>				
2504-S	Rear Axle Housing Gasket Set. (6 pcs.)	1	1912-27	3.95 set
2505	Rear Axle Shaft. Forged steel, ground bearing surface. USA.	2	1912-27	99.95 ea.
2505-WP	Wheel Puller. Screw-on. Our superior design will not strip the threads on your axle. Made in Ohio. Not usable on Model T steering.	1	1912-48	2.95 ea.
2505-SH	Rear Axle Shims. Tapered.	2	1912-48	1.25 ea.
2506	Rear Axle Shaft Hard Fibre Washer.	1	1909-27	.50 ea.
2507	Rear Axle Shaft Castle Nut.	2	1909-48	1.00 ea.
2508	Axle Shaft Roller Bearing. (2 per side)	4	1909-27	14.95 ea.
2509	Rear Axle Roller Bearing Sleeve. Fits right side outer & left side inner. Case hardened.	2	1909-27	26.95 ea.
2509-B	Rear Axle Roller Bearing Sleeve. Fits left side outer & right side inner. Case hardened.	2	1909-27	26.95 ea.
2509-P	Rear Axle Sleeve Puller. Pass Car only.	1	1909-27	14.95 ea.
2510	Rear Axle Housing Cap.	2	1909-27	1.95 ea.
2510-A	Steel Bearing Washer. Outer.	2	1909-27	.75 ea.
2510-B	Rear Axle Outer Roller Bearing Felt Washer.	2	1909-27	.60 ea.
2510-AM	Modern Outer Grease Seals. USA. Aluminum sealed caps complete with instructions.		1909-18	49.95 pr.
2511-B	Spring Washer. For leather rear axle seal. (Teeth & taper face in).	2	1926-27	1.00 ea.
2511-C	Leather Rear Axle Oil Seal. (Taper faces in).	2	1926-27	2.50 ea.
2511-M	Neoprene Rear Axle Inner Seal.	2	1909-27	16.95 pr.
2511-W	Inner Washer for Leather Oil Seal.	2	1926-27	.80 ea.
2514-C	Differential Case Bolt.	3	1922-27	.95 ea.
2515	Differential Case Bolt Nut.	3	1909-27	.50 ea.
2516	Rear Axle Inner Roller Bearing Felt Washer. Heavy duty.	6	1909-27	1.25 ea.
2518/97-B	Ring & Pinion Gear. Ratio of 11/40 (3.64:1 ratio) Made in USA.	1	1909-27	339.95 ea.
2518/97-BHS	Ring & Pinion Gear, 3 to 1 Ratio, 13/39. Made in USA.	1	1909-27	339.95 ea.
2519-A	Differential Lock Rings.	1	1909-27	1.25 pr.
2521-B	Differential Gear Key.	2	1911-27	.65 ea.
2526-B	Differential Spider. Good used.	1	1911-27	12.50 ea.
2528	Differential Thrust Washer. Machined brass.	2	1909-27	12.95 ea.
2528-RT	Roller Thrust Assembly Set. Long lasting roller bearing replaces #2528 & #2529 thrust plates & washers. Need 2 sets per Pass. Vehicle.	2	1909-27	59.95 set
2529	Differential Thrust Washer. Steel hardened.	4	1909-27	5.95 ea.
2531-B	Thrust Plate Pin.	6	1917-27	.65 ea.
2532	Differential Oil Plug w/ Fiber Gasket.	1	1909-27	2.95 set
2545	Rear Axle Grease Cup. Steel.	2	1909-27	2.95 ea.
2545-B	Rear Axle Grease Cup. Brass.	2	1909-15	7.95 ea.
2548	Radius Rod Nut.	2	1909-27	.75 ea.



2504-S



2505-WP



2508



2509-P



2510

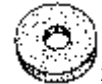

2510-B



2516



2518/2597-B



2526-B



2528-RT



2551

# Model T Parts

Part #	Description	Reqd.	Years	Price
<b>Rear Axle</b>				
2551	Rear Radius Rod Mounting Set. Contains all nuts, bolts & washers to mount radius rods to drivetrain.	1	1909-27	12.95 set
2551-B	Rear Radius Rod Bolt Nut.	4	1909-27	.75 ea.
2557	Rear Brake Cam. Right side.	1	1909-25	9.95 ea.
2557-B	Rear Brake Cam. Right side.	1	1926-27	16.50 ea.
2558	Rear Brake Cam. Left side.	1	1909-25	9.95 ea.
2558-B	Rear Brake Cam. Left side.	1	1926-27	16.50 ea.
2559	Rear Brake Cam Bushing. Steel.	2	1909-25	.80 ea.
2559-B	Rear Brake Cam Bushing. Brass.	2	1926-27	3.50 ea.
2560	Brake Drum Backing Plate w/Clips for Brake Shoe. Test fitted for alignment. Passenger side.	1	1926-27	32.50 ea.
2561	Brake Drum Backing Plate w/Clips for Brake Shoe. Test fitted for alignment. Driver's side.	1	1926-27	32.50 ea.
2563	Brake Camshaft Lever Pins. (2 pr. per car)	2	1909-25	.50 pr.
2563-B	Brake Camshaft Lever Pins. (1 pr. per car)	1	1926-27	.50 pr.
2564	Clevis Pin.	4	1909-27	.25 ea.
2566-A	Lined Rear Brake Shoes. (4 pc. set)	1	1909-25	104.95 set
2566-B	Hub Brake Band Assy. w/Springs less Lining.	2	1926-27	39.95 ea.
2566-D	Brake Lining Set. Woven wire impregnated as original w/ rivets. (Set for 2 wheels)	1	1926-27	57.95 set
2567	Brake Shoe Support Bolt.	2	1909-25	2.95 ea.
2568	Nut. For brake shoe support bolt.	2	1909-25	.75 ea.
2570-B	Brake Shoe Coil Spring.	4	1909-25	1.25 ea.
2570-C	Brake Shoe Coil Spring.	2	1926-27	1.50 ea.
<b>Universal Joint</b>				
2571	Universal Joint Assy. Excellent quality.	1	1909-27	124.95 ea.
2571-B	Universal Cap Bolt Set.	1	1909-27	5.95 set
2571-T	U Joint Wrench Used to rotate the drive shaft when installing the rear end.	1	1909-27	18.00 ea.
2574	Universal Joint Knuckle Pin.	1	1909-27	.25 ea.
2578	Universal Joint Housing Plug.	2	1909-27	2.75 ea.
2578-A	U-Joint Housing Plug. Domed. Early Style.	1	1909-18	1.50 ea.
2579	Universal Joint Grease Cup. Steel.	1	1916-27	9.95 ea.
2579-B	Universal Joint Grease Cup. Brass.	1	1909-15	9.95 ea.
2580	Universal Ball Cap Gasket.	2	1909-27	.75 ea.
<b>Drive Shaft</b>				
2581	Drive Shaft Housing Front Bushing. Brass.	1	1909-27	9.95 ea.
2583-G	Drive Shaft Bearing Housing Shim Gasket.	1	1909-25	.60 ea.
2586	Drive Shaft Roller Brg. Housing Set Screw.	1	1911-21	2.95 ea.
2587	Drive Shaft Roller Bearing.	1	1911-27	34.95 ea.
2588	Drive Shaft Bearing Housing Spacer Washer. Fits #2583 housing.	1	1911-20	3.95 ea.
2591	Drive Shaft Thrust Collar.	2	1911-27	13.95 ea.
2591-B	Drive Shaft Thrust Ball & Retainer.	1	1920-27	12.95 ea.
2595-B	Drive Shaft, New. High quality. USA. Don't ignore the stress of 80+ years on your old parts.	1	1909-27	189.95 ea.
2596	Drive Shaft Sleeve. Hardened. USA. Fits #2587 bearing.	1	1911-27	18.50 ea.
2598	Drive Shaft Castle Nut.	1	1911-31	2.95 ea.

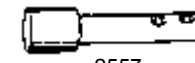

2557



2561

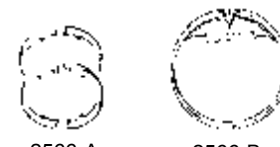

2566-A

2566-B

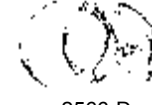

2566-D

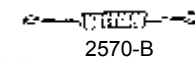

2570-B



2571



2579

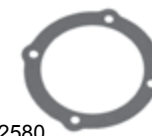

2580



2581



2587

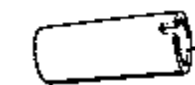

2596

# Model T Parts

Part #	Description	Reqd. Years	Price
--------	-------------	-------------	-------

## Front Axle

2598-B	Drive Shaft Pinion Key.	1 1911-27	1.95 ea.
2691	Castle Nut Set. For front axle & steering gear. (8 pc. set)	1 1909-27	3.95 set
2596-D	2696-D Spindle Arm. Left side.	1 1919-27	5.95 ea.
2697	Spindle Arm Castle Nut.	2 1911-27	.75 ea.
2706	Front Wheel Adjusting Cone. Left thread.	1 1909-25	1.50 ea.
2707	Front Spindle Nut. Right thread. Fits driver's side spindle.	1 1909-27	4.50 ea.
2708	Front Spindle Nut. Left thread. Fits passenger side spindle.	1 1909-27	4.50 ea.
2709	Front Spindle Washer.	2 1909-27	1.00 ea.
2710-S	Spindle Bolt Set. (King Pin Set) USA. Hardened & ground. (10 pc. set)	1 1917-27	49.95 set
2713	King Pin Bushing. Machined brass. USA.	4 1909-27	4.50 ea.
2714	Spindle Arm Bushing. Steel.	2 1909-27	.80 ea.
2715-D	Spindle Bolt & Tie Rod Bolt Oiler. Drive-in type. Flip top. Cadmium plated.	4 1915-27	.85 ea.
2718-S	Tie Rod Bolt Set. Includes bushings, nuts & flip top oilers.	1 1909-27	22.50 set
2718-T	Spindle Arm Bushing Driver. Also for front & rear spring perch bushing. Case hardened.	1 1909-27	7.95 ea.
2721-B	Tie Rod Ball Stud. (7/16" - 20). Tapered Shank.	1 1919-27	11.95 ea.
2722-B	Spindle Yoke Bolt Set. Special bolt, nut & cotter pin.	1 1919-27	1.95 set
2728	Ball Socket Cap. Steel. Fits #2725-B & C.	2 1909-27	10.95 ea.
2728-ACS	Accessory Ball Cap Repair Kit. Consists of seat, spring, threaded plug to rebuild the Apco spring loaded accessory style tie rod ball caps.	1 1911-27	6.95 kit
2729-B	Ball Socket Bolt & Nut Set. Holds ball socket Cap #2728. (1 per cap).	1909-27	2.00 set
2736	Front Radius Rod Ball Cap. Steel.	1 1909-27	12.95 ea.
2740	Speedometer Swivel "L" Bracket & Castle Nut. Fits Stewart U-joint.	1 1911-15	7.95 ea.
2741	Front Radius Rod Ball Cap Mounting Set. Fits 2737 & 2737-B. (7 pc. set)	1 1911-27	6.95 set



## Wheels & Tires

2800-21	Replacement Hickory Spoke for 4:40 x 21" Wheel. (8-15/16ths overall)	12 1925-27	14.95 ea.
2800/30	Replacement Hickory Spoke for 30 x 3-1/2" Wheels. (Not for 30 x 3" wheel)	12 1909-25	14.95 ea.
2805-S	Front Inner Hub Ball Bearing Assy. N.O.S.	2 1909-25	2.95 ea.
2806	Outer Race Bearing Retainer Ring. N.O.S.	2 1909-25	.50 ea.

# Model T Parts

Part #	Description	Reqd. Years	Price
--------	-------------	-------------	-------

## Wheels & Tires

2807	Inner Race Bearing Retainer Ring. N.O.S.	2 1909-25	.25 ea.
2809	Front & Rear Hub Felt Washer.	4 1909-25	.75 ea.
2816-B	Rear Axle Key. Hardened steel.	2 1912-27	.50 ea.
2818	Rear Brake Drum. For 5 stud wood wheel. Stamped steel. USA.	2 1909-25	37.95 ea.
2818-S	Rear Brake Drum. For 5 stud wire wheel. Stamped steel. USA.	2 1926-27	79.95 ea.
2818-W	Rear Brake Drum. For 6 stud wood wheel. Stamped steel. USA.	2 1926-27	79.95 ea.
2819-A	Hub Cap. Early script. Polished brass. Screw on cap for wood wheels.	1911-12	17.95 ea.
2819-B	Hub Cap. Script. Polished brass. USA. Screw on cap for wood wheels.	1913-16	18.95 ea.
2819-C	Hub Cap. Script. Chrome plated brass. USA. Screw on cap for wood wheels.	1917-27	19.95 ea.
2819-N	Hub Cap. Script. Nickel plated brass. USA. Screw on cap for wood wheels.	1917-27	19.95 ea.
2819-T	Hub Cap for Rear Wheels on 1 Ton TT Truck. Chrome plated brass. USA. Screw on cap for wood wheels.	2 1918-27	14.95 ea.
2819-W	Hub Cap. Ford wire wheel type. Nickerled. USA.	1926-27	16.95 ea.
2819-WB	Hub Cap. Ford wire wheel type. Polished brass. USA.	1926-27	12.95 ea.
2825	Rear Hub Bolt, 2-1/8" for Wood Wheels.	12 1911-27	.70 ea.
2825-B	Hub Bolt Jam Nut. Front & rear on wood wheels.	24 1911-27	.20 ea.
2826	Front Hub Bolt. 2". For wood wheels.	12 1911-27	.70 ea.
2833	Front Wheel Bearing Cup. Inner. Timken.	2 1919-27	19.95 ea.
2834	Front Wheel Bearing. Inner. Timken.	2 1919-27	26.95 ea.
2836	Front Wheel Bearing Cup. Outer. Timken.	2 1919-27	10.95 ea.
2837	Front Outer Roller Bearing. Driver's side. Right hand thread. Timken.	1 1919-27	89.95 ea.
2837/38	Front Outer Wheel Bearing. A budget pair of outer wheel bearings for casual driving use.	1 1909-27	59.95 pr.
2838	Front Outer Roller Bearing. Left hand thread. Passenger side. Timken.	1 1919-27	75.00 ea.
2841	Front Hub Dust Seal.	2 1919-27	5.95 ea.
2848-S	Demountable Rim Nut & Bolt Set. Cadmium plated. 16 bolts & 16 beveled nuts. Fits Hayes & Ford rims.	1 1919-27	46.95 set
2849-C to F	Spare Rim Clamps. N.O.S. Assorted styles - <i>Send sketch.</i>	1921-25	6.95 ea.
2854-B	Rear Crossmember. N.O.S.	1914-25	29.95 ea.
2855 to 60-B	Frame Brackets. N.O.S. No body brackets. Assorted styles - <i>Send sketch.</i>	1909-27	7.50 ea.
2884-S	Wire Wheel Lug Nut Set w/spare Lock Lug nut. Chrome plated. 23 pcs.	1 1926-27	179.95 set
2886	Wire Wheel Front Hub Grease Retainer. Script.	2 1926-27	9.95 ea.



# Model T Parts

Part #	Description	Reqd. Years	Price
<b>Inner Tubes</b>			
CC-1	Inner Tube, 30 x 3-1/2. Use in 30 x 3 & 31 x 4 Tires.	1909-25	21.00 ea.
CC-2	Inner Tube, 4:50/5:50 x 21".	1925-29	21.00 ea.
CC-3	Inner Tube, 4:75/5:50 x 19". (Also used in 5:00 x 20").	1930-31	21.00 ea.
CC-4	Inner Tube, 5:25/5:50/6:50 x 17" or 18".		21.00 ea.
CC-5	Inner Tube, 5:50/6:00 x 16".		21.00 ea.
CC-21T	Lucas Tire 440/450 - 21" "Olympic" Tread. This is a cost effective 4 ply nylon tire. Import.	1925-29	99.00 ea.
CC-303T	Wards Riverside 30 x 3 Tire. A very popular replacement tire of the period. 4 ply nylon.	1908-18	151.00 ea.
CC-3035T	Wards Riverside 30 x 3.5 Tire. A very popular replacement tire of the period. 4 ply nylon.	1909-25	152.00 ea.

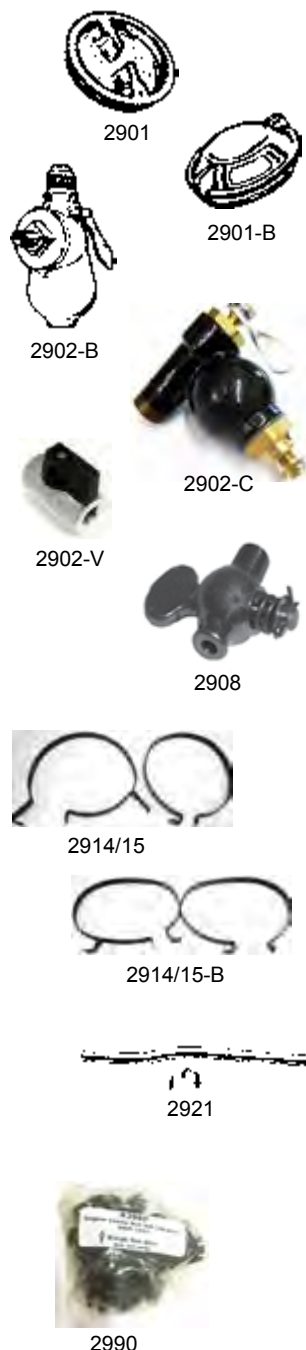

## Gas Tank

2901	Gas Cap w/ Gasket. Solid Brass. Early style.	1	1909-27	6.95 ea.
2901-B	Gas Cap. Brass plated. Later winged style.	1	1909-27	12.95 ea.
2901-G	Gas Cap Gasket. Fiberboard.	1	1909-27	.50 ea.
2902-B	Gasoline Sediment Bowl Assembly. Less drain petcock. Cast brass for early cars. Paint black for later cars. USA. (Use 2908 for drain petcock).	1	1909-27	69.95 ea.
2902-C	Gas Sediment Bowl & Shutoff Valve. All brass. Powder coated. USA.	1	1926-27	69.95 ea.
2902-V	Shut-off Valve. Modern ball valve rated 450 psi. Easy operation with no flow restriction in "On" position.	1	1909-27	13.95 ea.
2908	Drain Petcock for 2902-B Gasoline Sediment Bowl Assembly. Exact duplicate. USA.	1	1909-25	11.95 ea.
2910	Feed Pipe Pack Nuts. Brass.	1	1909-27	3.95 pr.
2913	Feed Pipe Pack Nut Felt Gaskets.	1	1909-27	.75 pr.
2914/15	Gas Tank Mounting Brackets for Round Tank.	1	1913-20	19.95 set
2914/15-B	Gas Tank Mounting Brackets for Oval Tank.	1	1920-25	19.95 set
2916	Gas Line to Frame Clamp w/ Mounting Bolt.	1	1921-27	3.95 ea.
2917	Upper Gas Tank Pads. This fits between top of tank & cowl supports that go from dash to firewall. Adhesive backing allows placing them on top of tank. Rubber.	1	1926-27	4.95 pr.
2919	Lower Gas Tank Pads. Rubber pads fit between bottom of gas tank & the tank support straps.	1	1926-27	10.95 pr.
2921	Gas Tank Overflow Pipe Assembly w/ Clamp. Fits cowl tanks.	1	1926-27	27.95 ea.

## Motor Cylinder

2990	Engine Castle Nut Set. (36 pcs.)	1	1909-27	12.95 set
3000-L	Engine Lift Eye.	1	1909-27	8.95 ea.
3000-S	Engine Green Paint. Spray can.		1925-41	6.95 ea.
3002-C	Head Gasket. Copper faced.	1	1909-27	33.95 ea.

# Model T Parts

Part #	Description	Reqd. Years	Price	
<b>Motor Cylinder</b>				
3002-FS	Complete Engine Gasket Overhaul Set. Includes copper head gasket.	1	1909-27	59.95 set
3002-M	Modern Steel Core Gasket with Silicone Coating. No other sealant required.	1	1909-27	28.95 ea.
3002-S	Head Gasket. Steel.		1909-27	17.95 ea.
3003-A	Cylinder Head Bolt. Shorter version used on low (early) heads.	15	1909-17	.85 ea.
3003-B	Cylinder Head Bolt. Longer version used on high heads.	15	1918-25	.95 ea.
3003-N	Cylinder Head Bolt. Nickel plated. Domed top bolt.	15	1918-27	1.75 ea.
3004	Cylinder Head Water Outlet Connection.	1	1909-16	23.50 ea.
3004-B	Cylinder Head Water Outlet Connection.	1	1917-25	29.95 ea.
3004-E	Cylinder Head Outlet Connection. The bronze cast will never rust. Excellent quality. USA.	1	1926-27	109.95 ea.
3005	Cylinder Water Outlet Gasket.	1	1909-27	.50 ea.
3008	Cylinder Water Inlet & Outlet Mounting Bolts. (4 pc. set)	1	1909-27	1.95 set
3009-C	Cylinder Front Cover. Used.	1	1919-26	15.00 ea.
3009-D	Cylinder Front Cover. Used.	1	1926-27	15.00 ea.
3012	Crankshaft Front Felt Seal. (2 pc. set)	1	1909-27	.75 set
3012-S	Modern Crankshaft Seal. This modern seal does the trick. Replaces 3012 felts. Instructions included. No modifications.	1	1909-27	6.95 ea.
3013	Cylinder Cover Gasket. For engine without generator.	1	1909-19	1.00 ea.
3013-B	Cylinder Cover Gasket. For engine with generator.	1	1919-27	2.25 ea.
3015	Cylinder Water Inlet. Cast iron. USA.	1	1909-27	32.95 ea.
3017	Timing Gear Cover. Used.	1	1919-27	9.95 ea.
3017-C	Timing Gear Cover Gasket. For engine with generator.	1	1919-27	.75 ea.
3018	Cylinder Water Inlet Gasket.	1	1909-27	.50 ea.
3019-B	Water Freeze Plugs. (Set of 3)	1	1914-27	1.00 set



## Motor Pistons & Connecting Rods

3021	Aluminum Pistons w/ Pins. T Slotted. Camground. Increases performance with less whip. Standard size. (Set of 4)	1	1909-27	94.50 set
3021-HC	High Compression Pistons. Special domed top Piston will increase Power & Compression Rings (not included). Not to be used with High Compression Head. <i>Specify Size: Std., .020, .030, .040, .060, .080</i>	1	1909-27	129.95 set
3021-20	Aluminum Pistons w/ Pins. (As above) .020 Size. (Set of 4)	1	1909-27	94.50 set
3021-30	Aluminum Pistons w/ Pins. (As above) .030 Size. (Set of 4)	1	1909-27	94.50 set
3021-40	Aluminum Pistons w/ Pins. (As above) .040 Size. (Set of 4)	1	1909-27	94.50 set
3021-60	Aluminum Pistons w/ Pins. (As above) .060 Size. (Set of 4)	1	1909-27	94.50 set

## Motor Pistons & Connecting Rods

Part #	Description	Reqd. Years	Price
3022	Piston Ring Set for Aluminum Pistons. Standard Size.	1 1909-27	59.95 set
3022-20	Piston Ring Set for Aluminum Pistons. .020 Size.	1 1909-27	59.95 set
3022-30	Piston Ring Set for Aluminum Pistons. .030 Size.	1 1909-27	59.95 set
3022-40	Piston Ring Set for Aluminum Pistons. .040 Size.	1 1909-27	59.95 set
3022-60	Piston Ring Set for Aluminum Pistons. .060 Size.	1 1909-27	59.95 set
3023	Piston Ring Set for Cast Iron Pistons. Standard Size.	1 1909-27	54.95 set
3023-HC	Piston Rings for High Compression Pistons. <i>Specify Size: Std., .020, .030, .040, .060, .080</i>	1 1909-27	49.95 set
3023-20	Piston Ring Set for Cast Iron Pistons. .020 Size.	1 1909-27	54.95 set
3023-30	Piston Ring Set for Cast Iron Pistons. .030 Size.	1 1909-27	54.95 set
3024	Connecting Rods. Rebabitted with spun alloy in Std., .010, 020. <b>Sold exchange only.</b> (Set of 4)	1909-27	295.00 set
3024-OD	Connecting Rod Oil Dips for 4 Rods.	1 1909-27	14.95 set
3025-N	Connecting Rod Nut Set. Special nuts for #3025 connecting rod bolt. (8 pc. set)	1 1909-27	4.95 set
3027-S	Connecting Rod Shims. Laminated. (Set of 8)	1909-27	7.95 set
3029	Connecting Rod Clamp Screw. (Wrist or piston pin locking bolt.) Drilled head.	1909-27	2.75 ea.

## Crank & Camshaft

3031	Rear Main Bearing Cap. Spun alloy babbit. <b>Sold exchange only.</b>	1 1909-27	61.95 ex.
3032	Crankshaft Front Main Bearing Cap. <b>Exchange.</b>	1 1909-27	52.50 ex.
3033	Crankshaft Center Bearing Cap. <b>Exchange.</b>	1 1909-27	52.50 ex.
3038/9-S	Main Bearing Shims. Front, Center & Rear. Laminated. (Set of 6 pcs.)	1 1909-27	7.95 set
3040	Crankshaft Starting Pin.	1 1909-19	.50 ea.
3040-B	Crankshaft Starting Pin.	1 1920-27	.75 ea.
3041-S	Modern Camshaft Seal. The modern way to keep the oil where it belongs. No modifications. Instructions included.	1 1909-27	6.95 ea.
3042-B	Front Cam Bearing, Short style. This bearing is used if the number 1 lobe is wider. USA.	1 1924-27	47.95 ea.
3042-TK	Cam Thrust Kit. Designed to eliminate noise at low RPM's.	1 1912-27	36.95 set
3043	Center Cam Bearing. USA.	1 1909-27	67.95 set
3044	Rear Camshaft Bearing. Bronze.	1 1909-27	3.95 ea.
3044-DR	Camshaft Rear Bushing Driver.	1 1909-27	7.95 ea.
3045	Camshaft Bearing Rings.	1 1909-27	3.95 pr.
3046	Camshaft Bearing Set Screws.	1 1909-27	7.95 pr.

## Crank & Camshaft

3047	Precision Machined Timing Gear. From Tenzaloy aluminum. Smooth & quiet under any load.	1 1909-27	59.95 ea.
3047-B	Fiber Camshaft Timing Gear. Bevel teeth. Size .003" oversize.	1 1909-27	59.95 ea.
3047-BA	New Improved Nylon 71/2 Degree Advanced Timing Gear w/special Nut. Made from orig. Ford drawings. Will give the engine noticeably more power.	1909-27	64.95 ea.
3047-BB	Standard Nylon Timing Gear w/special nut. This gear runs very quiet.	1 1909-27	64.95 ea.
3048-B	Steel Crankshaft Timing Gear. Bevel teeth. Standard size.	1 1909-27	19.95 ea.
3049	Camshaft Gear Dowel Pin.	2 1909-27	1.50 ea.
3050-B	Camshaft Gear Lock Nut.	1 1912-27	4.95 ea.
3051	Crankshaft Gear Key.	1 1909-27	.50 ea.

## Valves & Push Rods

3052	Valve. Intake & Exhaust. Standard. .312 dia. stem. Stainless steel.	8 1909-27	9.50 ea.
3052-B	Valve. Intake & Exhaust. .015 o.s. .327 dia. stem. Stainless steel.	8 1909-27	8.95 ea.
3052-C	Valve. Intake & Exhaust. .030 o.s. .342 dia. stem. Stainless steel.	8 1909-27	9.50 ea.
3052-G	Valve Setting Gauge. Stainless steel. Sets valve clearance by piston travel. Inst. incl.	1 1909-27	14.95 ea.
3052-R	Valve Guide Reamer. 1/64 o.s. USA. Reams worn guides to .3275.	1 1909-27	56.95 ea.
3053	Valve Spring Compressor Tool. Quality tested for proper fit. Instructions included.	1 1909-27	29.95 ea.
3054	Valve Springs. Standard. (set of 8)	1 1909-27	3.95 set
3056-S	Valve Spring Seats. (set of 8)	1 1909-27	6.95 set
3057-S	Valve Spring Pins. (set of 8)	1 1909-27	1.25 set
3058-AJ	Push Rods. Adjustable type. Std. size. (set of 8) .437 od. 7/16" dia.	1 1909-27	64.95 set
3058-BAJ	Push Rods. Adjustable type. 1/64" o.s. Stem. (set of 8) .4526 od.	1 1909-27	64.95 set
3058-CAJ	Push Rods. Adjustable type. 1/32" o.s.. Stem. (set of 8) .468 od.	1 1909-27	64.95 set

## Manifold

3060-B	Exhaust Manifold. Exact duplicate. USA.	1 1913-27	89.95 ea.
3061	Exhaust Pipe Pack Nut. Brass.	1 1909-27	11.95 ea.
3061-W	Exhaust Pack Nut Wrench. Made in USA. A much needed tool to tighten or remove the exhaust pack nut. Ductile iron.	1 1909-27	28.95 ea.
3062-HV	Aluminum Hi-Volume Intake Manifold. Provides a 53% increase in air flow. Fits all except vaporizer systems.	1 1909-27	114.95 ea.
3062-S	Exhaust & Inlet Gasket Set. E-Z drop-in style.	1 1909-27	2.95 set
3063/4-S	Manifold Gasket Set. Original type w/ 6 copper crush rings slipped over 6 steel gland rings. Aligns both manifolds with the block.	1 1909-27	9.95 set

# Model T Parts

Part #	Description	Reqd.	Years	Price
<b>Manifold</b>				
3063-CR	Copper Manifold Gasket Set. (6 pcs.) Heat resistant heavy copper ring style gasket set. Each ring fits into engine block & manifold.	1	1909-27	29.95 set
3063-S	Inlet & Exhaust Manifold Copper Crush Rings. (6 pc. Set)	1	1909-27	4.95 set
3064-S	Inlet & Exhaust Manifold Gland Set. (6 pc. Set)	1	1909-27	4.25 set
3066-B	Manifold Studs with Nuts. (8 pc. set) USA. Later straight shank stud. Works okay for all years.	1	1909-27	7.50 set

## Crankcase & Cylinder Valve Cover

3068-B	Brass Oil Cap. Script.	1	1909-14	22.95 ea.
3069	Dipstick Kit. Remove lower petcock for easy installation. Mounting bracket & tube are black powder coated.	1	1909-27	46.95 kit
3070/71-B	Crankcase to Cylinder Gaskets.	1	1909-27	2.50 pr.
3079	Crankcase Drain Petcock. Leakproof. Solid brass. USA. (Crankcase uses 2 of these to check the oil).	2	1909-27	8.95 ea.
3079-SG	Oil Sight Gauge. Brass.	1	1909-27	16.95 ea.
3080-RK	Oil Pan Drain Plug Repair Kit. Repair that leaky drain plug with the engine still in your car. Just a simple task. Instructions incl. Works for T & A pans.	1	1909-31	12.95 kit
3080-S	Oil Drain Plug & Fiber Gasket Set.	1	1909-27	2.95 set
3081-HV	High Volume Oil Line Kit. Delivers 10 times the oil to front of your engine, uphill or down, fast or parade slow. All needed parts including instructions. Best if done on workbench.	1	1909-27	87.95 kit
3081-HVB	High Volume Oil Line Brackets Only. Less Line and Fittings.		1909-27	33.95 pr.
3083	Crankcase Arm Blocks. Hardwood.	1	1909-27	3.95 pr.
3083-B	Engine Support Bolt Set. (12 pc. set)	1	1909-27	6.95 set
3085/86	Engine Splash Pans. These go between the motor & frame.	1	1909-27	67.50 pr.
3088-BCS	Engine Pan & Hood Sill Bolt & Nut Set w/ Washers.	1	1909-27	2.95 set
3100-MB	Oil Pan Mounting Bolt Set. The special head bolts & nuts with cover pins. (66 pcs.)	1	1911-27	38.95 set
3101-BS	Lower Oil Pan Bolt Set. (15 pcs.)	1	1912-27	2.50 set
3102-B	Crankcase Lower Cover Gasket.	1	1912-24	3.95 ea.
3102-C	Crankcase Lower Cover Gasket.	1	1924-27	3.95 ea.
3111-B	Valve Cover Gasket. (2 pc.)	1	1912-21	2.25 pr.
3111-C	Valve Cover Gasket.	1	1921-27	1.75 ea.

## Commutator

3158-M	Modern Stop/Brake Light Switch. Heavy duty. This kit will work with 6, 8, & 12 volt systems – positive or negative ground.	1	1909-27	36.95 kit
3158-SX	Stop Light Switch. Clamps on starter cover. Authentic duplicate.	1	1919-27	34.95 ea.

# Model T Parts

Part #	Description	Reqd.	Years	Price
<b>Commutator</b>				
3160	Distributor Ignition Assembly. New bolt-on distributor mounts on timing cover without modification. Works on 6 or 12 volt system. All necessary hardware & instructions included.	1	1912-27	359.95 ea.
3160-A	Distributor Plug Wire Set. Complete w/ rubber insulation boots. Fits 3160 distributor.	1	1912-27	32.95 set
3160-B	Spark Plug Wire Bracket Set. Original accessory fits under 2 head studs keeping distributor wires away from exhaust manifold.	1	1912-27	11.95 set
3160-C	Ignition Coil & Bracket. 6 volt. Used with our 3160 distributor ignition system. Bracket for firewall included.	1	1912-27	18.95 ea.
3160-E	Solid State Electronic Ignition. For our distributor or any Bosch 009 distributor. Uses 12v coil. Easier starting and smoother idle & running. Easy instruction.	1	1912-27	124.95 ea.
3162-B	Commutator Case Support Bolt. Used to bolt #3163, which holds the commutator to front of engine.	1	1919-27	2.25 ea.
3163	Commutator Case Spring. Holds commutator to front of engine. Used with #3162-B	1	1912-27	1.95 ea.
3165	Roller Type Timer. High Quality. USA.	1	1911-27	79.95 ea.
3170	Timer Calibrating Gauge. Authentic tool for Tiger Timer.	1	1911-27	1.25 ea.
3176-C	Commutator Oiler. Drive-in, flip top type. Cadmium plated.	1	1917-27	.85 ea.
3177	Timer Felt Washer. Heavy duty.	1	1912-27	.60 ea.
3206/7	Timer Brush Cap & Pin Set. Fits on end of camshaft.	1	1911-27	1.00 set
3207	Brush Cap Pin.	1	1911-27	.25 ea.
3220	Timer Lock Nut on Camshaft.	1	1911-27	2.75 ea.
3222	Commutator Shield. Brass. Fits between timer & cover.	1	1911-27	2.95 ea.

## Magneto & Flywheel

3250-A	Magneto Coil Assembly. Double stack style. Rebuilt & tested. <b>Sold exchange only.</b>	1	1915-18	249.95 ex.
3250-D	Magneto Coil Assembly. Single stack style w/ notch for starter. Rebuilt & tested. <b>Sold exchange only.</b>	1	1919-27	235.00 ex.
3257	Magneto Support Spool.	16	1909-27	1.50 ea.
3260-A	Magneto Post. Replacement type.	1	1909-25	17.95 ea.
3260-B	Magneto Post. Replaces shorted or damaged assembly.	1	1926-27	16.95 ea.
3268	Flywheel Ring Gear. Drilled & hardened. USA.	1	1919-27	47.95 ea.
3270	Flywheel Cap Screw. Drilled head.	4	1909-27	3.95 ea.
3271	Flywheel Dowel Pin.	2	1909-27	1.95 ea.
3272-C	Magneto Coil Support Shim. Steel.	4	1909-27	1.00 ea.
3272-LS	Magneto Coil Shim. Laminated brass.	4	1909-27	1.50 ea.
3277	Magneto Magnet Clamp. Stamped steel. Exact duplicate.	16	1911-27	2.95 ea.
3278-S	Brass Magnet Screws. (set of 16)	1	1911-27	10.95 set
3279	Magneto Post Gasket.	1	1909-25	.35 ea.

Part #	Description	Reqd.	Years	Price
<b>Transmission</b>				
3304	Transmission Reverse Gear Bushing. Oil impregnated SAE 841 sintered bronze.	1	1909-27	11.95 ea.
3309	Transmission Slow Speed Gear Bushing. Oil impregnated SAE 841 sintered bronze.	1	1909-27	7.95 ea.
3312	Transmission Brake Drum Lug Shoe.	6	1926-27	1.95 ea.
3313	Triple Gear. Good used. (Will need rebushed)	3	1909-27	19.95 ea.
3314-1/2	Transmission Triple Gear Bushing. Flanged. Oil impregnated SAE 841 sintered bronze.	3	1911-27	5.95 ea.
3314-D	Triple Gear Bushing Driver. Hardened steel.	1	1911-27	7.95 ea.
3315	Triple Gear Pin. Hardened steel. Slight oversize provides snug fit (3 pc. set).	1	1909-27	12.95 set
3315-STD	Triple Gear Pin, Hardened Steel. Std. size (3 pc. Set)	1	1909-27	32.50 set
3318	Transmission Driven Gear Key.	2	1909-27	.35 ea.
3320-C	Transmission Driven Gear Sleeve Bushing. Oil impregnated SAE 841 sintered bronze.	1	1909-27	5.95 ea.
3320-D	Transmission Driven Gear Sleeve Washer. (Brake drum thrust washer) (3 pc. set)	3	1917-27	2.50 set
3327-B	Transmission Driving Plate Bushing. Oil impregnated SAE 841 sintered bronze.	1	1909-27	3.95 ea.
3328	Transmission Clutch Disc. Round. Replaces warped/worn originals with 80 to 96 years of use. USA.	12	1909-27	5.95 ea.
3328/9	Jack Rabbit Accessory Clutch Set. Provides smooth shifting & accurate neutral. Used with 9 stock hex plates. Total 17 plates.	1	1909-27	89.95 set
3329	Transmission Clutch Disc. Hex type. Replaces warped/worn originals with 80-96 years of use. USA.	13	1909-27	4.50 ea.
3331	Transmission Gear Shaft. This is the main shaft that the drums are mounted on. USA.		1909-27	210.00 ea.
3333	Transmission Clutch Disc. Drum Key.	1	1909-27	.50 ea.
3334	Trans. Clutch Drum Set Screw. N.O.S.	1	1909-27	1.95 ea.
3336	Transmission Clutch Push Ring.	1	1909-27	17.50 ea.
3337	Transmission Clutch Finger. N.O.S.	3	1909-25	4.95 ea.
3337-1/2	Transmission Clutch Finger Screw. N.O.S.	3	1909-25	1.00 ea.
3340	Transmission Clutch Spring. (Good used)	1	1909-27	12.95 ea.
3340-N	Transmission Clutch Spring. New. Ideal for Watts, Turbo & Ford Clutches. Provides 110- 115 #'s of force at 2" compression length.	1	1909-27	33.95 ea.
3344	Transmission Clutch Shift.	1	1909-27	12.95 ea.
<b>Transmission Cover</b>				
3363	Transmission Cover Front Felt Strip.	1	1909-27	.95 ea.
3367-BS	Trans. Cover Door Screw Set. (6 per set)	1	1912-27	1.50 set
3369	Universal Ball Cap. Front. Spun alloy babbitt.	1	1909-27	62.95 ex.
3369-A	Sealed Ball Bearing 4th Main Cap. Reduces vibration & crankshaft fatigue. Engine disassembly & machining required. Instructions included. No core needed.	1	1909-27	109.95 ea.



Part #	Description	Reqd.	Years	Price
<b>Transmission Cover</b>				
3369-S	Special Sealed Bearing 4th Main Cap. Works like #3369-A except no disassembly required. Can be installed with engine in car. Instructions included.	1	1909-27	146.95 ea.
3377-B	Transmission Cover Gasket. (2 pc. set)	1	1909-27	3.95 set
3379-B	Transmission Cover Door Gasket.	1	1911-27	1.00 ea.
3380	Starter Drive Cover.	1	1919-27	11.95 ea.
3381	Starter Drive Cover Gasket.	1	1919-27	.50 ea.
<b>Transmission Control &amp; Bands</b>				
3403	Clutch Lever Screw & Nut Set. Fits #3402. Used to adjust clutch release travel.	1	1909-27	1.00 set
3405	Clutch Lever Pin & Clutch Release Fork Pin.	1	1909-27	.30 ea.
3411	Clutch Lever Clevis Pin. Fits #3402-D.	1	1913-27	.25 ea.
3414-C	Quick Change Ear. Used. <i>Specify wide or narrow.</i>	3	1926-27	8.95 ea.
3415	Transmission Band Washer.	2	1909-27	1.25 ea.
3416-BK	Wear-Ever Kevlar Band Lining w/ Rivets & Instructions. (3 pc. set)	1	1909-25	97.50 set
3416-D	Transmission Band Lining w/ Rivets. Woven style. (Set of 3)	1	1926-27	36.95 set
3416-DK	Wear-Ever Kevlar Band Lining w/ Rivets & Instructions. (3 pc. set)	1	1926-27	105.00 set
3416-SR	Band Lining Rivet Set. (set of 24 pcs.)	1	1909-27	1.25 set
3416-W	Transmission Band Adjusting Wrench & Holder. Chained together to prevent loss.	1	1909-27	18.95 ea.
3419	Slow Speed Adjusting Screw & Special Nut.	1	1909-25	11.95 ea.
3419-B	Slow Speed Adjusting Screw & Special Nut.	1	1926-27	11.95 ea.
3420	Transmission Band Adjusting Screw Nut.	1	1909-27	1.00 ea.
3425-S	Transmission Band Springs. (Set of 3)	1	1909-27	1.85 set
3426	Transmission Band Adjusting Nut.	2	1909-27	1.65 ea.
<b>Transmission Pedal &amp; Controller Shaft</b>				
3434-B	Lettered Pedal B with Weld on Head Only. Made of ductile iron.	1	1909-15	12.95 ea.
3434-C	Lettered Pedal C with Weld on Head Only. Made of ductile iron.	1	1909-15	12.95 ea.
3434-R	Lettered Pedal R with Weld on Head Only. Made of ductile iron.	1	1909-15	12.95 ea.
3437	Brake & Reverse Pedal Support Bolt.	2	1909-25	1.75 ea.
3437-B	Support Bolt Nut. Also fits #2514-C.	1	1909-27	.50 ea.
3437-C	Brake & Reverse Pedal Support Bolt.	2	1925-27	2.95 ea.
3439-ES	Pedal Pads. Lettered black rubber. (Set of 3)	1	1909-25	9.95 set
3439-LS	Pedal Pads. Lettered black rubber. (Set of 3)	1	1926-27	9.95 set
3441	Brake & Clutch Pins. (Set of 3)	1	1909-27	.75 set
<b>Handbrake</b>				
3445/7	Slow Speed Connector & Clevis. (2 pc. set)	1	1909-27	9.95 set
3447	Slow Speed Connector Clevis. (Also for brake rods.)	1	1909-27	6.95 ea.
3448	Brake Quadrant. 4 hole style. Die stamped steel. Made in USA.	1	1909-25	12.95 ea.

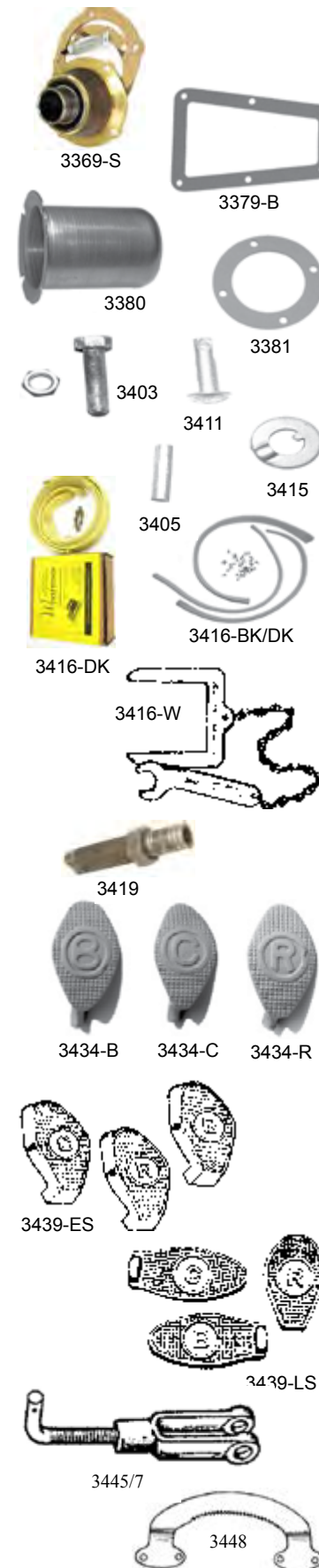

Part #	Description	Reqd.	Years	Price
<b>Handbrake</b>				
3448-B	Brake Quadrant. 2 hole style. Die stamped steel. USA.	1	1926-27	12.95 ea.
3458	Handbrake Lever Pawl. Die stamped steel. Made in USA.	1	1909-27	5.95 ea.
3459	Hand Brake Lever Pawl Pin.	1	1909-27	.75 ea.
3463	Hand Brake Spring. Tempered steel.	1	1909-27	1.95 ea.
3463-RE	Hand Brake Lever Spring. Snap-on. Extra replacement type.	1	1909-27	1.50 ea.
3466	Hub Brake Lever Pins. (Set of 2)	1	1909-27	.75 set
3468-B	Rear Brake Rods. (Requires 2 #3447 clevis (not included))	1	1909-25	73.50 pr.
3468-C	Rear Brake Rods. Requires 2 #3447 clevis (not included)	1	1926-27	36.95 pr.
3470/71	Brake Rod Support Brackets. Brackets attach to rear radius rods & support brake rods to rear brake levers Right & left w/hardware.	1	1914-27	19.95 pr.
<b>Steering</b>				
3500-C	Steering Column Support w/ Grooved Lower Clamp for Horn Wire. This rivets to dash panel.	1	1922-25	79.95 ea.
3500-CB	Steering Support Lower Half with Groove for Horn Wire.	1	1922-25	9.95 ea.
3504	Steering Gear Cover. Solid brass.	1	1909-14	32.95 ea.
3509	Steering Gear Quadrant. Polished brass.	1	1909-14	32.95 ea.
3511	Steering Wheel Nut. Low crown. Polished brass.	1	1909-16	7.50 ea.
3511-B	Steering Wheel Nut. High type. Black oxide.	1	1917-27	2.95 ea.
3511-C	Steering Wheel Nut. High type. Chromed.	1	1917-27	8.95 ea.
3517/19	Steering Pinion Gears & Pins w/ Drive Pinion Shaft. 4 to 1 Ratio. (7 pc. set) (Will not interchange with 1926-27)	1	1909-25	69.95 set
3517/19B	Steering Pinion Gears & Drive Pinion Shaft with Pins. 5 to 2 Ratio. (7 pc. set) (Will not fit earlier gear case).	1	1926-27	69.95 set
3518	Steering Pinion Gear Pin Set. Holds #3517 gears on steering post #3516. (3 pc. set)	1	1909-27	2.25 set
3520	Steering Drive Pinion Gear Key. Stainless.	1	1909-27	1.00 ea.
3523	Steering Gear Post Castle Nut. (Also fits radius rod bolt)	1	1909-27	.75 ea.
3526	Spark & Gas Rod Knobs. Early years only.	1	1909-14	22.50 pr.
3527	Spark & Throttle Rod Springs.	1	1909-27	1.00 pr.
3528-S	Spark & Gas Rod Spring Cups. USA.	1	1909-27	5.50 pr.
3529	Spark & Gas Lever Pins. USA.	1	1929-27	.50 pr.
3530	New Bronze Spark Lever Arm. All holes drilled.	1	1909-27	8.95 ea.
3531	New Bronze Throttle Lever Arm. Holes drilled.	1	1909-14	9.75 ea.
3531-A	Bronze Throttle Lever Arm. Holes drilled.	1	1915-27	8.95 ea.
3532-B	Spark & Throttle Rods Guide. Die stamped. Fits approximately midway of firewall and steering bracket.	1	1916-27	5.95 ea.
3534-B	Commutator Pull Rod. Non-ball joint type.	1	1912-25	4.95 ea.
3534-C	Commutator Pull Rod.	1	1926-27	4.95 ea.
3535	Carburetor Pull Rod.	1	1909-25	3.50 ea.

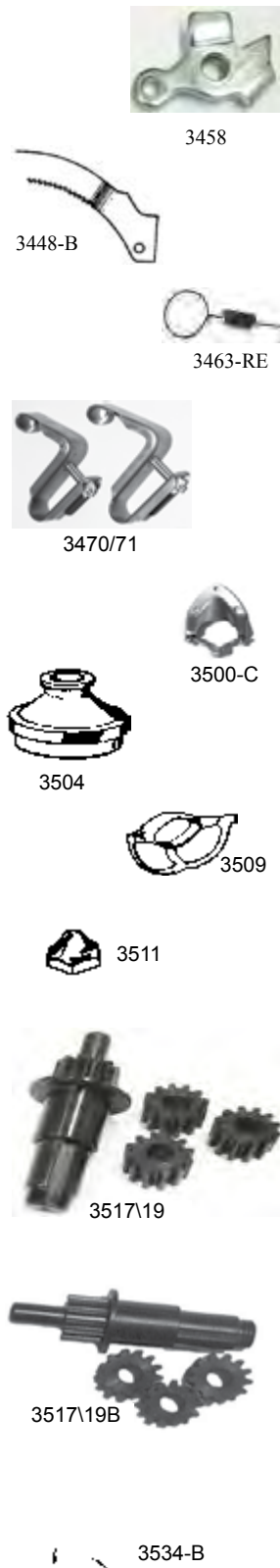



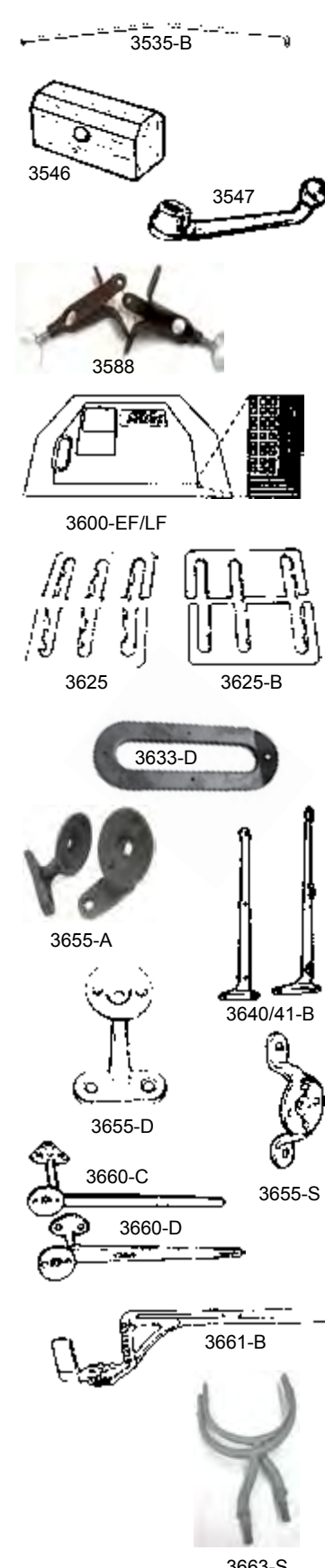





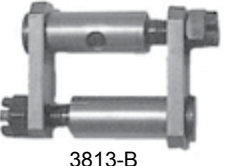

Part #	Description	Reqd.	Years	Price
<b>Steering</b>				
3535-B	Carburetor Pull Rod. Non-vaporizer carb. (All except Fordor Sedans)	1	1926-27	4.95 ea.
3540	Steering Gear Bracket Long Bolt & Nut. Used with 2 #3541.	2	1909-27	1.25 ea.
3541	Steering Gear Bracket Short Bolt & Nut. Used with #3540.	2	1911-27	1.95 ea.
3544	Steering Bracket Felt Washer.	1	1909-27	.60 ea.
3545-A	Steering Bracket Bushing. Large bushing used from 1909-21. Often uses 2.	1	1909-25	5.95 ea.
3545-B-2	Steering Bracket Bushing.	1	1926-27	4.95 ea.
3546	Steering Bracket Block. Hardwood.	1	1909-27	1.75 ea.
3547	Pitman Arm. Replaces that worn steering arm & improves steering. USA.	1	1909-27	46.95 ea.
3548	Steering Gear Ball Arm Key.	1	1909-27	.50 ea.
3588	Top Bow Clamps w/ Wing Screws. Holds top to windshield posts.	1	1923-27	49.95 pr.
<b>Floor Mats</b>				
These Floor Mats are of the same design that was on the car when it left the factory. All are made of high quality heavy rubber with a sharp design. Mats have large borders to fit all styles.				
3600-AF	Front Floor Mat. Open Car.	1	1909-14	34.50 ea.
3600-EF	Front Floor Mat. Open Car.	1	1915-25	44.95 ea.
3600-LF	Front Floor Mat. Open Car.	1	1926-27	39.95 ea.
3610-ER	Rear Floor Mat. Open Car.	1	1915-25	29.95 ea.
3610-LR	Rear Floor Mat. Open Car.	1	1926-27	31.95 ea.
<b>Brackets</b>				
3625	Pedal Floor Board Trim.	1	1909-25	17.95 pr.
3625-B	Pedal Floor Board Trim.	1	1926-27	18.95 pr.
3633	Floorboard Trim Plate for Emergency Brake Handle.	1	1909-25	2.95 ea.
3633-D	Emergency Brake Trim Plate. Correct front angle.	1	1926-27	3.75 ea.
3640/41-B	Firewall Brackets. Wood firewall to frame.	1	1911-16	69.95 pr.
3655-A	Side Light Brackets. Designed for use with oil side lights on Open Cars & Roadster Pickups. USA.	1	1923-25	24.95 pr.
3655/6	Oil Lamp Brackets. Steel. Used with lamps that have blade type mounting brackets. Has round bolt holes.	1	1911- mid '14	34.95 pr.
3655-D	Side Light Brackets for Truck & Depot Hack.	1	1916-27	54.95 pr.
3655-S	Side Light Brackets for Sedan & Coupe.	1	1916-27	49.95 pr.
3660	Tail Lamp Bracket. Roadster.	1	1909-14	16.95 ea.
3660-B	Tail Lamp Bracket. Touring.	1	1913-14	17.95 ea.
3660-C	Tail Lamp & License Bracket. Touring.	1	1915-19	31.50 ea.
3660-D	Tail Lamp & License Bracket. Roadster.	1	1915-19	29.95 ea.
3661-B	Neverout Bracket. Solid brass.	1	1909-14	105. ea.
3663-S	Carbide Headlight Forks. High quality castings. 6-1/2" between forks. Incl. hardware.	1	1911-14	89.95 pr.

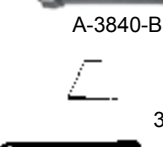
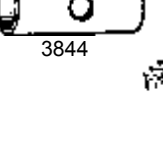
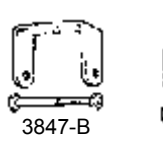



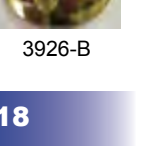









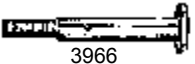

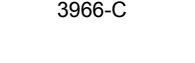

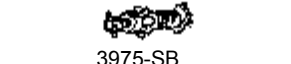
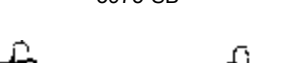

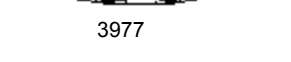
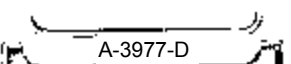

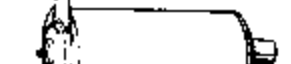
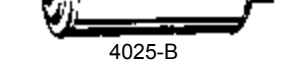
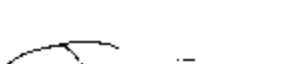
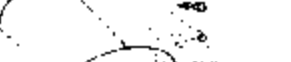
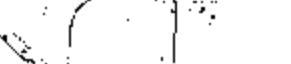
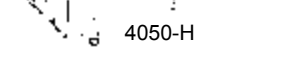

# Model T Parts

Part #	Description	Reqd. Years	Price
<b>Front &amp; Rear Springs</b>			
 3811	Front Spring Center Bolt & Nut. 7 leaf size.	1 1909-25	1.00 ea.
3811-C	Front Spring Center Bolt & Nut. 8 leaf size.	1 1926-27	1.00 ea.
 3813-B	Front Spring Shackle Set. L style. For 1 front end.	1 1909-27	39.95 set
3815	Castle Nut Set. Used with front & rear shackles. (8 pcs.)	1 1909-27	2.50 set
 3817-B	Front & Rear Spring Hanger Oiler. Brass. Screw-in turn type. Fits front & rear spring hangers & spindle bolt & tie rod bolt.	4 1909-16	6.95 ea.
 3817-N	Front & Rear Spring Hanger Oiler. Nickel plated. Screw-in turn type.	4 1915-16	4.95 ea.
 3818-B	Front Spring Perch. Right hand. Exact duplicate. Made in USA.	1 1919-27	38.95 ea.
 3819-B	Front Spring Perch. Left hand. Exact duplicate. Made in USA.	1 1919-27	38.95 ea.
 3820	Front Spring Perch Bushing.	4 1909-27	.40 ea.
 3820/46	Front Shackle Bushings & Oilers. (8 pc. set)	1 1909-27	3.50 set
 3821-B	Front Spring Perch Special Nut.	2 1919-27	2.50 ea.
 3823	Front Spring Pad.	1 1909-27	1.00 ea.
 3837	Rear Spring Center Bolt w/ Nut. Square head. 8 leaf size.	1 1909-27	1.50 ea.
 3838-B	Rear Spring Center Bolt w/ Nut. Square head. 9 leaf size.	1 1922-27	1.50 ea.
3840-B	Rear Spring Shackle Set. L style. For 1 rear end.	1 1909-27	35.95 ea.
3842	Rear Spring Pad.	1 1909-27	1.25 ea.
3844	Rear Spring Bushing.	4 1909-27	.65 ea.
3844/46	Rear Shackle Bushings & Oilers. (8 pc. set)	1 1909-27	4.95 set
3846	Spring Perch Oiler. Flip top type. Cadmium plated.	4 1917-27	1.25 ea.
3847-B	Front Spring Clamp Set w/ Bolts & Nuts.	1 1909-27	3.95 set
3848-B	Rear Spring Clamp Set w/ Bolts & Nuts.	1 1909-27	5.95 set
<b>Starting Crank</b>			
3901-B	Crank Handle & Pin. Aluminum. Duplicate of original.	1 1911-14	19.95 ea.
3903	Starting Crank Handle Sleeve.	1 1909-22	1.95 ea.
3905	Starting Crank Ratchet Pin.	1 1909-27	.75 ea.
3905-SN	Quick Change Crank Pin. Accessory pin that holds ratchet on crank. Just unsnap to remove ratchet for easy belt change.	1 1909-27	6.95 ea.
3908	Crank Spring.	1 1909-27	.50 ea.
3909	Starter Crank Handle Spring.	1 1915-22	.50 ea.
<b>Radiator</b>			
3924	Radiator Filler Neck. Solid brass, 2-1/2" tall. Used 1911-16, also on 1909-10 radiators. Threaded for any 'T' radiator cap.	1 1909-16	32.95 ea.
3926	Radiator Cap. Brass. High fin.	1 1909-12	12.95 ea.
3926-B	Radiator Cap. Polished Brass.	1 1913-16	9.95 ea.
3926-C	Radiator Cap. Chromed.	1 1917-27	19.50 ea.
3927	Radiator Cap Gasket.	1 1909-27	.25 ea.

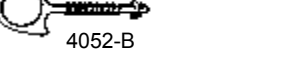
# Model T Parts

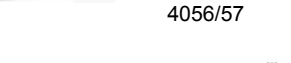
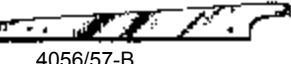
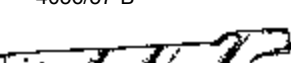
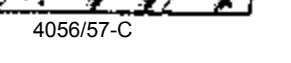







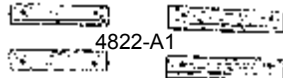

Part #	Description	Reqd. Years	Price
<b>Radiator</b>			
 3932	Radiator Rod. Threaded. 23" long. (Cut to size)	1 1909-27	5.35 ea.
 3939	Water Pipe on Side of Engine. Black Powder Coated.	1 1909-27	8.95 ea.
 3939-WP	Water Pipe. Special length pipe for Model T with water pump. (Not used w/ our 3950).	1 1910-27	8.95 ea.
 3940-OS	Radiator Drain Petcock, Leakproof. Solid brass. Exact duplicate. USA. (Also used as 2908 gas sediment bulb & 3079 crankcase oil measure).	1 1909-27	11.95 ea.
 3944-R	Radiator Hose Set, Red. Heavy duty. (3 pcs.)	1 1909-27	11.95 set
 3945-S	Radiator Hose Clamp Set. Original type & style. Galvanized. (6 pc. set)	1 1909-31	4.95 set
 3947-MB	Radiator Shell, Black. Modern style. Fits stock radiator & all short Walker radiators. Includes a custom lower valance. <i>Not a stock shell.</i>	1 1917-23	179.95 set
 3947-MC	Radiator Shell, Chrome. Modern style. Same as above only chrome.	1 1917-23	229.95 set
 3950	Leakless Water Pump Assembly w/ Sealed Bearings & Stainless Steel Components. Includes thermostat, lower hose, gaskets, and easy instructions. No modifications.	1 1909-27	239.95 ea.
 3952	Water Pump Packing. Teflon rope strip. (Cut in single rings & stagger joints when installing.)	1 1909-27	2.95 ea.
 3954	Thermostat. For use with a water pump. 180 dg. Fits between water outlet & head.	1 1909-27	9.95 ea.
 3956	Thermostat. For engines without a water pump. 160 dg. Fits between water outlet & head.	1 1909-27	9.95 ea.
 3961-C	Fan Blade Assembly. Stamped steel 4 blade fan. Fits 3962-B fan hub. Black powder coated.	1 1920-27	14.95 ea.
 3962-A	Fan Hub Ball Bearing Insert Unit. Replaces original bushings w/ permanently lubricated ball bearings. No modifications. Instructions incl.	1 1916-19	46.50 ea.
 3962-B	Ball Bearing Fan Hub Assembly. New. Permanently lubricated sealed ball bearings. Correct contour & raised edges extends fan belt life. No modifications. Instructions incl.	1 1920-27	76.50 ea.
 3963-A	Crankshaft Pulley. Small size. Raised edges & correct crown for positive fan belt control. Special spring pin & instructions included. No modifications required.	1 1909-19	62.50 ea.
 3963-B	Crankshaft Pulley. Large size. Raised edges & correct crown for positive fan belt control. Special spring pin & instructions included. No modifications required.	1 1920-27	72.50 ea.
 3964	Fan Belt, 23". 1 pc. 5 ply construction.	1 1909-16	18.95 ea.
3964-B	Fan Belt, 25-7/8". 1 pc. 5 ply construction.	1 1917-20	19.95 ea.
3964-C	Fan Belt, 27". 1 pc. 5 ply construction.	1 1920-25	12.50 ea.
 3964-D	Fan Belt, 31". 1 pc. 5 ply construction. Fits 1909-16 w/ water pump	1 1909-16	21.75 ea.
3964-F	Fan Belt, 32". 1 pc., 5 ply construction. (Also fits 1917-25 w/ water pump)	1 1926-27	13.95 ea.

# Model T Parts

Part #	Description	Reqd.	Years	Price
<b>Radiator</b>				
 3964-G	Fan Belt, 33-3/4". 1 pc. 5 ply construction. Fits 1917-27 with various pulley sizes.	1	1917-27	21.95 ea.
 3964-WP	Fan Belt, 36". For cars with water pumps. 1 pc. 5 ply construction.	1	1926-27	23.50 ea.
 3966	Fan Shaft. Hardened & ground. Correct threaded end. (4-1/4" O.A.)	1	1909-20	17.95 ea.
 3966-B	Fan Shaft. Hardened & ground. Correct threaded end. (3-3/4" O.A.)	1	1920-25	19.95 ea.
 3966-C	Fan Shaft. Hardened & ground. Correct threaded end. (4-3/8" O.A.)	1	1926-27	21.95 ea.
 3975-SB	Fan Bracket. (Good used).	1	1917-25	6.50 ea.
 3968	Fan Bracket Mounting Bolt.	1	1909-25	4.50 ea.
 3973	Fan Adjustment Bolt & Nut.	1	1909-25	1.25 set
 3974-B	Fan Pulley Bushings, Oilite. Front & rear.	1	1920-27	4.95 pr.
 3975	Radiator Mounting Kit w/Leather Pads. Early style.	1	1909-16	10.95 kit
 3975-SA	Radiator Mounting Kit.	1	1917-25	16.95 kit
 3975-SB	Radiator Mounting Kit. (18 pcs.)	1	1926-27	17.95 kit
 3977	Radiator Front Splash Apron.	1	1923-25	28.95 ea.
 3977	Radiator Front Splash Apron.	1	1923-25	28.95 ea.
 3977-A	Radiator Apron. Low style, plain steel.	1	1916-23	54.95 ea.
 3977-D	<b>NEW</b> Radiator Apron Trimstrip. Chrome.	1	1926-27	18.95 ea.
 3977-E	Radiator Front Splash Apron. As original. Includes crank handle guide & slots for 3977-D chrome trim strip.	1	1926-27	42.95 ea.
 3981	Fan Pulley Gasket.	1	1920-27	.35 ea.
 3982	Fan Shaft Cap & Felt Washer Set.	1	1920-27	1.25 set
 3983	Fan Shaft Felt Washer.	1	1920-27	.50 ea.
<b>Muffler</b>				
 4025	Muffler w/ Cast Iron Ends. Take apart style. Our own product. Made in Ohio.	1	1909-27	59.95 ea.
 4025-B	Muffler w/Stamped Steel Ends. Take apart style. Made in Ohio.	1	1909-27	37.95 ea.
 4037-B	Exhaust Pipe. Aluminized steel to reduce rusting.	1	1909-27	17.95 ea.
<b>Hood</b>				
 4050-G	Hood. Steel with steel handles. 6 louvers. High type. For vehicles w/ cowl width of 28". (Also fits 1924-27 TT trucks) [side panel 14" at rear & 13 1/2" at front]	1	1924-27	399.95 ea.
 4050-H	Hood. Steel. 18 louvers, Steel handles. (Not for TT Trucks) [side panel 14 3/4" at rear & 14 1/4" at front]	1	1926-27	399.95 ea.
 4052-B	Hood Hook w/ Spring. Cast steel.	4	1917-27	5.95 ea.
 4053-B	Hood Clip Spring.	4	1917-27	.50 ea.
 4056/57	Wooden Hood Blocks. Early cars used wooden blocks for the hood to rest on. We provide solid cherry for the early "T."	1	1909-16	41.95 pr.
 4056/57-B	Hood Blocks. Die Stamped Steel. Fits low hood.	1	1917-23	34.95 pr.
 4056/57-C	Hood Blocks. Die stamped steel. High hood.	1	1923-25	41.95 pr.

# Model T Parts

Part #	Description	Reqd.	Years	Price
<b>Hood</b>				
 4056/57-D	Hood Blocks. Die stamped steel.	1	1926-27	42.95 pr.
 4060-S	Radiator Shell & Cowl Lacing w/ Rivets. 12' long x 1/8" x 3/8" wide.	1	1909-25	9.95 set
 4060-XS	Radiator Shell & Cowl Lacing w/ Rivets. 3/8" & 5/8" wide.	1	1926-27	8.95 set
 4073/4-B	Hood Block Support. Drilled & counter bored hardwood. (4 pc. set)	1	1924-25	11.95 set
 4073/6-C	Hood Block Support. Drilled & counter bored hardwood. (4 pc. set)	1	1926-27	9.95 set
<b>Carburetor—Miscellaneous</b>				
 4129	Carburetor Control Rod w/ Brass Knob.	1	1909-16	31.95 ea.
 4129-A	Carburetor Adjusting Rod.	1	1909-25	4.95 ea.
 4129-B	Carburetor Adjusting Rod & Knob. 31-1/4" long. Cut to fit. All bodies. Used with #4132, #6161-B & #6213-B.	1	1925-27	19.95 ea.
 4131	Carburetor & Vaporizer Adjusting Rod Sleeve. Used with #4132, #6161-B & #6213-B.	1	1925-27	14.95 ea.
 4132	Universal Joint Spider Swivel. Cast metal. Fits. #6213-B, #6279 & #4133. Oversize to compensate for wear.	1	1925-27	1.50 ea.
 4133	Carburetor Adjusting Swivel & Needle. For NH carburetors.	1	1926-27	32.95 ea.
 4134	Carburetor to Manifold Flange Gasket.	1	1909-27	.30 ea.
 4431	Choke Wire. Brass. Through radiator to choke lever.	1	1909-27	2.50 ea.
 4582	Carburetor Hot Air Pipe.	1	1912-25	12.95 ea.
 4583	Priming Bell Crank.	1	1919-25	4.50 ea.
 4588-B	Carburetor Choke Rod & Knob. 13-9/16" long.	1	1919-22	6.95 ea.
 4588-D	Carburetor Choke Rod & Knob. 13-1/16" long. Used with steel dash.	1	1923-25	6.95 ea.
 4588-E	Carburetor Choke Rod & Knob. 17-1/8" long. Used with steel dash.	1	1923-25	6.95 ea.
 4588-F	Carburetor Choke Rod & Knob. 16-1/16" long. Tudor & Fordor Sedan.	1	1923-25	6.95 ea.
 4591	Choke Lift Sleeve. Fits carb. rod under hood.	1	1925-27	2.95 ea.
<b>Fender Brackets</b>				
 8786-R	Right Fender to Tail Lamp Bracket. Bracket used when mounting above light on right rear fender.	1	1925-27	10.95 ea.
 4804-BS	Rear Fender Bracket to Frame Bolt Set. (18 pc. set)	1	1909-25	8.95 set
 4806-B	Fender Eye Bolt & Nut.	4	1909-25	7.95 ea.
 4850-BS	Front Fender Bracket to Frame Bolt Set. (18 pc. set)	1	1909-25	8.25 set
 4858	Front Fender Brackets.	2	1926-27	36.95 ea.
<b>Running Boards</b>				
 4811	Running Boards. Torpedo style. Trophy quality.	1	1910-11	160.00 pr.
 4812	Running Boards. Rib style. Trophy quality.	1	1909	199.95 pr.
 4812-A	Running Boards. Die stamped. Trophy quality.	1	1911-12	199.95 pr.
 4812-B	Running Boards. Die stamped. Trophy quality.	1	1913-25	199.95 pr.
 4812-C	Running Boards. Die stamped. Trophy quality.	1	1926-27	199.95 pr.

Part #	Description	Reqd. Years	Price
<b>Running Boards</b>			
 4812-SP	Running Board Step Plates. Rectangular script area. Die cast aluminum. USA.	1 1915-27	47.95 pr.
 4813-BS	Special Bolt Set. Running boards to brackets.	1 1909-27	3.95 set
4814-L/R	Running Board Splash Aprons. Open Car.	1 1915-16	195.95 pr.
4815-CL/R	Running Board Splash Aprons. Roadster, Touring, Coupe, Sedan.	1 1917-25	229.95 pr.
 4815-FL/R	Running Board Splash Aprons. Fits all body styles.	1 1926-27	229.95 pr.
 4822-A1	Running Board Blocks. As original. Drilled hardwood. (Set of 4)	1 1909-25	6.95 set
4822-A2	Running Board Blocks. As original. Drilled hardwood. (Set of 4)	1 1926-27	6.95 set
<b>Ignition Coil</b>			
 5001	Copper Coil Box Contact Strip Set. (9 pcs)	1 1915-27	14.95 set
5001-A	Coil Box Interior Wood Set. Plywood, drilled & grooved.	1 1915-25	13.95 set
5001-AM	Modern Plastic Coil Box Kit. Not affected by moisture putting an end to misfiring. Hardware included.	1 1915-25	44.95 kit
5001-B	Coil Box Interior Wood Set. Plywood, drilled & grooved.	1 1926-27	11.95 set
5001-BM	Modern Plastic Coil Box Kit. Not affected by moisture putting an end to misfiring. Hardware included.	1 1926-27	44.95 kit
 5004	Coil Box Lid. Used on all slant top coil boxes. Die stamped steel. Ford script.	1 1915-25	27.95 ea.
5004-B	Coil Box Lid w/ Latch Clips. Stamped steel. Fits Passenger Cars & Trucks.	1 1926-27	29.95 ea.
 5004-G	Rubber Water Gasket for Coil Box Lid.	1 1926-27	2.50 ea.
5005	Coil Box Tube. Renew that old coil box with all new, white coil box tubes. U.S.A.	1 1914-27	1.35 ea.
5005-L	Coil Box Bolts & Nuts. Copper plated steel. Set includes 10 bolts & 20 nuts.	1 1909-25	4.50 set
5005-S	Coil Box Bolt Set. Copper plated steel. Set has 10 bolts & 20 nuts. Fits later box.	1 1926-27	4.50 set
5005-TN	Thumb Nut. Brass nut used to attach wires to the coil box.	1 1909-13	1.10 ea.
 5005-W	Coil Box Tube Insulator Washers. Fiber insulating washers for the tubes & bolts that connect the wiring to the coil box (20 pcs.)	1 1909-27	2.75 set
5006	Coil Box Ignition Key. Flat style. Brass. Die stamped.	1 1914-22	3.95 ea.
5006-P	Early Coil Box Key. The pin style key for early switch that mounts on front of coil box.	1 1909-14	3.95 ea.
 5007	Coil Unit. Genuine K. W. Moisture proof case.	4 1914-27	89.95 ea.
 5007-C	Coil Capacitor. Internal capacitor of correct capacity used when rebuilding KW coils. USA.	1 1909-27	2.50 ea.
 5007-KWS	Wood Cased KW Coil with Thumb Screw Connectors. These coils are ideal for Hit & Miss engines and Flame Throwers.	1 all	89.95 ea.

Part #	Description	Reqd. Years	Price
<b>Ignition Coil</b>			
 5007-R	Reconditioned Wood Coils. <i>Exchange only.</i> All coils are cleaned, new capacitor installed, re-potted, new points & hardware and finally-fine tuned.	1909-27	59.95 ea.
 5007-WR	Wood Cased KW Coil. High quality wood case stamped KW. Made in USA. The coil has been precisely adjusted on a hand cranked magneto tester. (Tampering w/ coil adjustment voids warranty).	1913-27	79.95 ea.
 5008/9	Coil Points. Genuine K W. (2 pc. set)	4 1914-27	8.95 set
 5012	Ignition Switch Assembly with Keys. Painted black. (Ammeter not included).	1 1919-25	82.50 ea.
 5012-B	Ignition Switch Assembly with Keys. Chrome plated. (Ammeter not included).	1 1926-27	82.50 ea.
 5012-C	Ignition Switch Repair Kit. This kit is for clip style case with tabs to hold the parts in the back of the switch.	1 1919-27	19.95 kit
 5012-K	Ignition Switch Repair Kit. This kit is for the pin style case with pins to hold the parts in the back of the switch.	1 1919-27	19.95 kit
 5012-T	Ignition Switch Tumbler with 2 keys.	1 1919-27	15.95 kit
 5013-B	Switch Key. Ford script. From 51 to 74. <i>Specify.</i>	1 1919-27	7.95 ea.
 5013-F	Key Fob, leather. Ford Model T.	1 1909-27	3.95 ea.
 5014	Starter Switch. Exact duplicate.	1 1919-27	14.95 ea.
 5014-M	Starter Switch & Extension Set. Modern style includes extension to clear floorboards. Trouble free quality product. USA.	1 1919-27	27.95 set
 5015	Starter Button Extension. To clear floor board.	1 1919-27	4.95 ea.
<b>Ammeter</b>			
 5016	Ammeter 20-20. Exact reproduction. Rugged D'Arsonval movement gives steady readings & extreme accuracy. Ford Script.	1 1919-25	54.95 ea.
 5016-B	Ammeter, 20-20. (Requires #5017-D if used in 1919-25 switch plate)	1 1919-27	7.95 ea.
 5016-F	Ammeter, 20-20. Ford script. (Requires #5017-D if used in 1919-25 switch plate)	1 1919-27	9.95 ea.
 5016-L	Ammeter 20-20. Illuminated. Ford Script.	1 1919-25	62.50 ea.
 5017-D	Ammeter Adapter Plate. To adapt small ammeter to early dash panel.	1 1919-25	3.50 ea.
 5018	Starter Drive Assembly. Complete.	1 1919-27	75.00 ea.
5019	Starter Drive Head.	1 1919-27	7.95 ea.
5020	Starter Drive Key.	1 1919-27	.25 ea.
 5021-BG	Bendix Gear with Balance Ring Set. Replaces weakest part of starter drive.	1 1919-27	21.95 set
 5021-SL	Starter Bendix Sleeve. Replaces weakest part of bendix drive.	1 1919-27	11.95 ea.
5022	Starter Bendix Spring. USA.	1 1919-27	7.95 ea.
 5023-S	Starter Bolt & Washer Set.	1 1919-27	2.50 set

# Model T Parts

Part #	Description	Reqd. Years	Price
<b>Wiring</b>			
5026/29-B	Spark Plug Wire Set. Oak brown covered wire with brass terminals.	1 1909-25	15.95 set
5026/29-BB	Spark Plug Wire Set. Oak brown covered wire with brass terminals.	1 1926-27	15.95 set
5027	Magneto to Coil Box Wire. Oak brown covered wire with brass terminals.	1 1909-27	4.95 ea.
5029-0	9 mm <b>Bulk</b> Ignition Wire less Ends. Oak/Black Tracer.	1 1909-27	1.50 ft.
5029-B	9 mm <b>Bulk</b> Ignition Wire less Ends. Black/Double Red Tracer.	1 1909-27	1.50 ft.
5029-T	Spark Plug Terminal. Original style brass. U.S.A.	1 1909-27	.60 ea.
5030	Commutator Wire. 5 wire. (Without starter)	1 1909-22	16.95 ea.
5031	Commutator Wire. 7 wire.	1 1919-25	32.95 ea.
5031-B	Commutator Wire. 4 wire.	1 1926-27	12.95 ea.
5033-C	Wire Clip. May need as many as 7 per car.	1 1919-27	1.25 ea.
5038	Ammeter to Switch Wire.	1 1919-27	1.95 ea.
5039	Wiring Diagram. Fully detailed 24" x 28" poster.	1 1919-25	5.95 ea.
5039-B	Wiring Diagram. Fully detailed 24" x 28" poster.	1 1926-27	5.95 ea.
5040/40-B	Horn Wiring Set.	1 1919-27	6.95 set
5041	Lighting Wire Harness. 5 wire.	1 1919-25	23.95 ea.
5041-E	Lighting Wire Harness. 8 wire.	1 1926-27	44.95 ea.
5042	Switch Wire Harness. This 7 wire harness runs from terminal block to back of switch.	1 1919-27	22.95 ea.
5044	Terminal Block with Mounting Bolts.	1 1922-27	8.95 ea.
5046	Battery Cable to Starter Switch. 30" long.	1 1919-27	10.95 ea.
5047-C	Battery Cable to Switch Support Bracket with Grommet.	1 1920-27	4.25 ea.
5049-B	Ground Connector Strap. Braided ground strap with tinned battery terminal. 7" long.	1 1919-27	11.95 ea.
5051	Starter Switch to Starter Motor Cable. 30".	1 1919-27	8.95 ea.
5051-OR	Starter Switch Cable. Cloth covered as original w/correct ends.	1 1919-27	13.95 ea.
5053	Cable Loom. Fits over #5051 starter cable from switch to starter motor.	1 1919-27	5.95 ea.
5055	Generator Cutout Negative ground. Fits on top of generator. Quality foreign product. (Note: Clip goes on side closest to mounting ears. This is arm side).	1 1919-27	38.95 ea.
5055-CK	12 Volt Conversion Kit. Fits all Model T's with negative ground and 6 volt generator.	All years	99.95 kit
5055-R	Voltage Regulator w/ Ford Script. Negative ground. No more sticking points. (Will not fit model A's or V-8's)	1 1919-27	84.50 ea.
5056	Starter Motor Mounting Gasket.	1 1919-27	.75 ea.
5057	Generator Gasket.	1 1919-27	.75 ea.

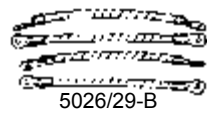

5039



5039-B

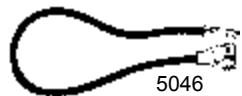

5046

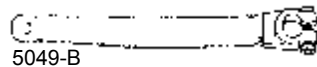

5049-B



5051



5055



5055-CK



5055-R

# Model T Parts

Part #	Description	Reqd. Years	Price
<b>Starter</b>			
<b>Important Notice</b> Rebuilt Starters and Generators require a re-buildable core. We cannot process your order without receiving a re-buildable core. Gaslight is unable to extend a core charge.			
5059-S	Starter Drive Cover Special Screws & Lock Washers. (8 pc. set)	1 1919-27	1.95 set
5062	Starter Motor Mounting Set. (8 pc. set)	1 1919-27	1.50 set
5099	Starter Motor. Rebuilt. <b>Sold exchange only.</b> Complete with all new or refurbished parts. New field coils, bearing, brushes and post kit installed. The armature is turned, polished, ground tested, then growl tested for shorts. Does not include bendix drive.	1 1919-27	279.95 ea.
5101	Coverband with Nut & Bolt. Fits both starter & generator. Duplicate of original.	1 1919-27	8.95 ea.
5104-S	Starter Brush Set. Authentic. (Set of 4)	1 1919-27	15.95 set
5105	Starter Rear Bushing. Drive end. Brass.	1 1919-27	8.95 ea.
5105-S	Modern Starter Seal. Keeps the oil where it belongs. No modifications. Inst. included.	1 1919-27	5.95 ea.
5106	Starter Front Bushing. Brush end. Brass.	1 1919-27	5.95 ea.
5107	Starter Field Coil Set.	1 1919-27	59.95 set
5109	Starter Terminal Outer Insulator.	1 1919-27	2.95 ea.
<b>Generator</b>			
5119	Generator. Rebuilt. <b>Sold exchange only.</b> <b>Remove your gear first.</b> Rebuilt with all new or refurbished parts. New field coils, bearing, brushes and post kit installed. Armature is turned, polished, ground tested and then growl tested for shorts. Negative ground.	1 1919-27	229.95 ex.
5119-A	Alternator. 12 volt. Complete gear driven Delco unit w/ internal fan & regulator. 1 year warranty. No modifications needed. Instructions included. USA.	1 1919-27	239.95 ea.
5119-A6	Alternator. 6 or 12 volt. Complete gear driven unit. Simply change the regulator to go from 6 to 12 volt without changing any of your existing wiring. 5 yr. guarantee against defects.	1 1919-27	229.95 ex.
5119-A12	Alternator. 6 or 12 volt. Complete gear driven unit. Simply change the regulator to go from 6 to 12 volt without changing any of your existing wiring. 5 yr. guarantee against defects.	1 1919-27	229.95 ex.
5121	Generator Bearing. Small. Brush end.	1 1919-27	3.95 ea.
5122	Generator Bearing. Large. Gear end. Double shielded.	1 1919-27	3.50 ea.
5125/26-S	Generator Brush Set. (3 pcs.)	1 1917-26	6.95 set
5128	Generator Small Bearing Felt.	1 1919-27	.50 ea.
5131-A	Large Brush Holder on End Plate.	2 1919-27	9.95 ea.
5131-B	Small Brush Holder on End Plate.	1 1919-27	9.95 ea.
5132	Insulator for Generator Brush Plate. 2 different insulators as originally used in assembling the generator. USA.	1 1919-27	2.95 pr.
5133	Generator Outer Terminal Insulator.	1 1919-27	2.95 ea.
5136	Generator Gear to Shaft Retaining Pin.	1 1919-27	.50 ea.
5137	Generator Gear.	1 1919-27	19.95 ea.
5143	Generator Field Coil Set. (4 coil set)	1 1919-27	59.95 set



5099



5101



5104-S

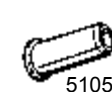

5105



5106



5107



5119



5119-A

5122

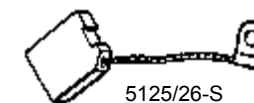

5125/26-S



5132



5133



5137

**We have many USED Model 'T' Parts.**

**www.gaslightauto.com**

**gaslight@ctcn.net**

**800.242.6491**

# Model T Parts

Part #	Description	Reqd.	Years	Price
<b>Battery &amp; Spark Plugs</b>				
5150-B	Battery Bracket Assembly. Die stamped steel. Exact duplicate. (Not for TT Truck)	1	1919-27	39.95 ea.
5152	Battery Clamp Set.	1	1919-23	5.95 set
5152-B	Battery Clamp Set.	1	1921-27	5.95 set
5201	Champion #25 Spark Plug. Long reach for model T. 1 piece style.	4	1909-27	18.95 ea.
5201-A	Spark Plug. 1/2" Pipe thread. 1 piece style.	4	1909-27	5.50 ea.
5201-X	Champion X Spark Plug w/ Brass Top as Original. Trophy style required for judging.	4	1909-27	32.95 ea.
5202	Spark Plug Adapters. (4 pc set). Adapts T head to accept 14mm spark plugs.	1	1909-27	14.95 set
<b>Carburetor</b>				
6200	New Carburetor, Modern Design. Has fuel/air mixture that increases engine performance by 20-30%, while using less fuel. Has nylon float, neoprene float valve, etc. New carb. Advanced rod. Instructions included. No modifications needed. See below for air cleaner.	1	1909-27	279.95 ea.
6200-AC	New Air Cleaner for Modern Carburetors. Keep All dirt out of your engine with our New modern air cleaner for our New modern carburetor #6200. (Not for original carbs.)	1	1909-27	44.95 ea.
6200-C	New Holley NH Carburetor. Authentic. USA. Includes long choke & throttle levers, #6213 spray needle assembly & NH data plate 100% compatible with today's fuel.	1	1920-25	299.95 ea.
6200-D	New Holley NH Carburetor. Authentic. USA. Includes short choke & throttle levers, #6213-B spray needle assembly and NH date plate. 100% compatible with today's fuel. (Not for vaporizer system)	1	1926-27	299.95 ea.
6200-DP	Data Plate w/Pins. Holley NH Carburetor. This plate used before the word Ford was added. #6200-C & #6200-D.)	1	1919-22	1.95 ea.
6200-DPB	Data Plate for NH & Holley Carburetors. Used on Carbs with both Ford & Holley.	1	1916-27	1.50 ea.
6200-DPV	Data Plate fo Holley Vaporizer.	1	1926-27	4.95 ea.
6200-FV	Fuel Shut-Off Valve. Replaces elbow fitting where gas line connects.	1	1909-27	22.95 ea.
6200-K-L4	Kingston Needle, Seat & Gasket Set for Model L4 Carb. This is ball type seat valve.	1	1921-26	21.95 set
6200KL-4	Kingston L4 Needle Seat & Gasket Set. Has steel needle & seat. Includes all gaskets.	1	1921-26	12.95 set
6200-NH	Gross-jet Needle & Seat with Gasket Set. Provides positive fuel level in your clean carb.	1	1920-27	24.95 set
6200-NHV	Viton tipped needle & gaskets. Fits NH or Vaporizer Carbs. <b>State which one.</b>	1	1920-27	21.95 set
6200-RNH	Rebuilt Ford NH & Holley NH. <b>*Must have core before shipment*</b>	1	1920-25	189.95 ex.

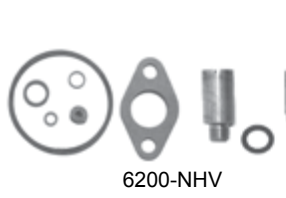
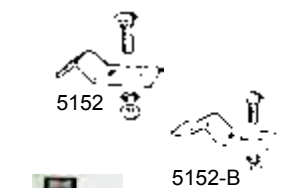
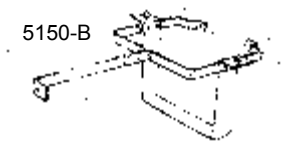

# Model T Parts

Part #	Description	Reqd.	Years	Price
<b>Carburetor</b>				
6201	Carburetor Float w/ Lever. Brass plated. For NH carb. Also fits vaporizer carburetor. (Set float 1/4" below flange).	1	1920-27	16.95 ea.
6201-G	Cork Float w/ Screws. Use your old hinge. For Holley 'G' carburetor only.	1	1918-20	17.95 ea.
6201-L-2	Cork Float w/ Screws. Use your old hinge. For Kingston L-2 carburetor.	1	1917-21	17.95 ea.
6202-C	Float Chamber Steel Bowl. Center drain style. Holley NH Carburetor.	1	1923-27	7.95 ea.
6203-G	Carburetor Gasket Set for Holley 'G' Carb.	1	1913-21	1.95 set
6203-L	Carburetor Gasket Set for Kingston 'L' Carb.	1	1912-21	1.95 set
6203-L4	Carburetor Gasket Set for Kingston 'L-4' Carburetor	1	1921-26	1.95 set
6203-NH	Carburetor Gasket Set for Ford & Holley NH Carburetor.	1	1920-26	1.95 set
6203-V	Carburetor Gasket Set for Holley Vaporizer Carburetor.	1	1926-27	1.95 set
6206-A	Throttle Lever & Brass Shaft with correct adj. screws for NH & Model G Carburetor.	1	1914-23	18.95 ea.
6206-B	Choke Lever & Brass Shaft with Torsion Spring for NH & 'G' Holley Carburetor.	1	1914-23	15.95 ea.
6206-C	Throttle Lever & Brass Shaft with Correct Adjusting Screws for Holley & NH Carburetor.	1	1923-26	18.95 ea.
6206-D	Choke Lever & Brass Shaft with Torsion Spring Attached for NH Carburetor.	1	1923-26	18.50 ea.
6208	Adjusting Needle Clamp Nut for NH Carburetor. Use with #6213.	1	1920-25	4.95 ea.
6208-B	Spray Needle Adjusting Nut for NH & L-4 Carburetors. Use with #6213-B.	1	1925-27	3.95 ea.
6208-H	Spray Needle Clamp Nut. (Used with 6213-G spray needle)	1	1912-19	3.95 ea.
6208-L	Spray Needle Adjusting Nut. Kingston L-4 Carbs. (Used w/#6213-K)	1	1915-26	6.95 ea.
6209	Carburetor Throttle and/or Choke Plate with Retaining Clip for NH Carburetors. Brass.	1	1920-27	2.95 ea.
6213	Spray Needle Assembly for NH Carburetor #6200-C. Use with #6208 clamp nut.	1	1920-25	9.95 ea.
6213-B	Spray Needle Assembly for NH #6200-D. Use w/#6208-B clamp nut.	1	1925-27	18.95 ea.
6213-G	Ford & Holley "G" Spray Needle Assembly. Made in the USA. Use with 6208-H.	1	1914-21	9.95 ea.
6213-K	Spray Needle Assembly. USA. Kingston L, L2 & Early L4 Carb. Use w/#6208-L nut.	1	1910-25	10.95 ea.
6214-B	Spray Nozzle. NH & Vaporizer Carburetors.	1	1920-27	7.95 ea.
6216/21	Carburetor Drain Valve for NH Carburetor. Non-vaporizer type. Brass.	1	1920-26	12.95 ea.
6216/91	Carburetor Drain Valve for Vaporizer Carburetors. Brass.	1	1926-27	12.95 ea.
6256	Vaporizer Choke Lever Assembly. Brass shaft with black oxidized steel levers. Correct spring is included. USA.	1	1926-27	13.95 ea.
6258-H	Choke Lever Spring. Fits Holley Model G & NH Carburetors.	1	All	1.50 ea.



Part #	Description	Reqd.	Years	Price
<b>Carburetor</b>				
6258-K	Choke Lever Spring. Fits Kingston L & L-4 Carburetors.	1	All	1.00 ea.
6258-V	Choke Lever Spring. Fits vaporizer carburetor.	1	1926-27	1.00 ea.
6259	Vaporizer throttle lever assembly. Brass shaft with black oxide steel lever & screw. USA.	1	1926-27	8.95 ea.
6269	Vaporizer Outlet Tube. Brass. Correct flange. USA.	1	1926-27	3.95 ea.
6271	Vaporizer Outlet Tube Brass Knurled Nut. USA.	1	1926-27	4.95 ea.
6273	Vapor Heating Plate for Vaporizer Carburetor. Stainless steel. (Raised corrugated area faces engine.) USA.	1	1926-27	2.50 ea.
6276	Vaporizer Primary Air Tube. Stainless. USA. (Tube runs from bowl up to the butterfly plate)	1	1926-27	5.95 ea.
6277	Vaporizer Heating Plate Support. USA. (Coil spring fits around & supports #6276 air tube.)	1	1926-27	1.95 ea.
6278	Vaporizer Adjusting Needle Nut. Machined brass. Used with #6279. USA.	1	1926-27	4.50 ea.
6279	Vaporizer Adjusting Needle Assy. Brass shaft & stainless needle. Used w/ #6278. USA.	1	1926-27	14.95 ea.
6283	Vaporizer Carb. Adjusting Needle Seat. USA.	1	1926-27	6.95 ea.
<b>Lights</b>				
2122-X	Headlight Loom Bushings. Fits hood shelf at front to prevent chafing of wiring.	1	1917-25	3.95 pr.
3158-M	Modern Stop/Brake Light Switch. Heavy duty. This kit will work with 6, 8, & 12 volt systems positive or negative ground.	1	1909-27	36.95 kit
3158-SX	Stop Light Switch. Clamps on starter cover. Authentic duplicate.	1	1919-27	34.95 ea.
5055-CK	12 Volt Conversion Kit. Fits all Model T's with negative ground and 6 volt generator.		All years	99.95 kit
6405-CX	Glass Tail Lamp. Cup style. Clear glass.	1	1924-27	9.95 ea.
6484-BRX	Tail Lamp Lens. Red. For electric tail lamp. 3" diameter.	1	1919-25	6.95 ea.
6484-CX	Tail Lamp Lens. Red celluloid. 2-3/4" dia. Used in 6405-CX.	1	1926-27	1.25 ea.
6574-AX	Headlamp Socket. Exact duplicate. Double contact. Used with generator system.	2	1919-27	14.95 ea.
6575	Electric Headlight Rims. Polished brass.	1	1915-16	57.50 pr.
6575-AX	Electric Headlight Rims. Painted black.	1	1916-25	52.50 pr.
6575-BX	Electric Headlight Rims. Nickel plated.	1	1926-27	57.50 pr.
6576-HX	Headlamp Lens. Ford script. 'H' style. Refracting lens for improved lighting.	2	1915-27	19.95 ea.
6578-X	Headlight Gaskets. Cord style.	1	1915-27	1.75 pr.
6586-X	Headlight Lens Retainer Wire.	2	1915-27	4.50 ea.
6590-AX	Headlamp Reflectors. Chromed steel.	1	1915-27	59.95 pr.
6591-S	Focusing Screws & Springs for #6574-AX. (4 pc. set)	1	1919-27	1.95 set
6592	Headlamp Plug w/ Thimble. Double contact.	1	1915-27	22.50 pr.
6593	Tail Light Plug w/ Thimble. Single contact.	1	1919-27	10.95 ea.
7650	Tail Lamp Wire Bushing Kit. (6 pcs. kit)	1	1919-27	15.95 kit

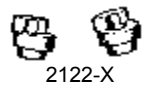

Part #	Description	Reqd.	Years	Price
<b>Lights</b>				
7669-RX	Tail Lamp Assembly. Electric. Exact duplicate. Made in USA. (Painting required).	1	1919-24	44.95 ea.
8786-CX	Tail Lamp & License Bracket. Complete original style tail light w/ left side fender mounting bracket. (Order 8786-R if mounting on right fender)	1	1925-27	79.95 ea.
8786-R	Right Fender to Tail Light Bracket. Used when mounting above light on right rear fender.	1	1925-27	10.95 ea.
8786-TS	Modern Turn Signal Switch. Using the tail lights to alert drivers behind you. Mounts on spark control lever. 7 wire with 12V flasher. Includes instructions & wiring diagrams.	1	1926-27	149.95 ea.
A-13000	Headlamp Bulb. 50-32 cp. 6 volt. Dbl. contact. The higher candlepower offers better visibility & safety. Ensures other drivers will see you when using the brakes.	2	1919-34	1.25 ea.
A-13000-HAL	Halogen Head Light Bulb. Uses Orig. style base for easy installation.		1919-34	27.00 ea.
A-13465	Stop Lamp Bulb. 21 cp. 6 volt.	1	1926-32	1.10 ea.
A-13465-HP	Brighter Stop/Brake Bulb. 6 volt. 30 cp.	1	1926-42	1.25 ea.
A-13466	Light Bulb. This bulb is used in several places in A., T & V-8 Fords. (Cowl, Dash, Dome, Park & Taillight.) 3 cp. 6 Volt.		1919-36	.95 ea.
<b>Door Handles &amp; Deck Lock &amp; Key</b>				
D-100	Outside Door Handle. Closed Car.		1924-27	29.95 ea.
D-101	Door Lock & Keys. Fits Closed Car.		1924-48	12.95 ea.
D-102	Window Riser Handle. Standard style. Closed Cars.		1924- mid '30	10.95 ea.
D-103	Window Regulator Assy. Right side. 3 hole mounting for steel doors. Coupe & Tudor.		1924-27	36.50 ea.
D-104	Window Regulator Assy. Left side. 3 hole mounting for steel doors. Coupe & Tudor.		1924-27	36.50 ea.
D-105	Door Latch Knob. Closed Car & Truck.		1915-29	4.95 ea.
D-106	Door Garnish Moldings. Coupe & Tudor Sedan.	1	1926-27	104.95 pr.
D-107	Door Bumper Set. Coupe & Tudor Sedan. (10 pcs)		1926-27	7.95 set
D-108	Panel Grommets & Ratchet Nails. Holds door & kick panels in place. (10 nails & 10 grommets per pack) Open Cars & Trucks.	1	1926-29	7.95 pkg.
D-111	Escutcheon Plate. Chromed. Fits behind window riser handle. Closed Car.	1	1923-48	4.50 ea.
D-112-WF	Inside Door Window Frames w/ Brackets & Fittings. 1926-27 Coupe & Tudor & 1927-29 Closed Cab Truck.	1		134.95 pr.
D-114	Felt Glass Channel Strips, 48" long. Closed Car & Truck.	1	1917-29	39.95 pr.
D-115	Door Latch Repair Kit. Contains all springs, screws & rivets needed to repair both door latches. Coupe, Tudor & Closed Cab Truck.	1	1926-27	15.95 kit
D-116	Hinge to Door Hardware. Screws & star washers to fasten three hinges to one door.	1	1926-27	2.95 set

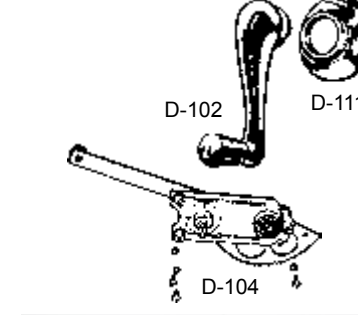
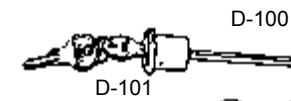
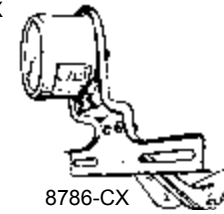
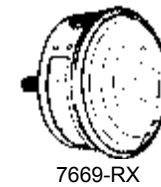

# Model T Parts

## Door Handles & Deck Lock & Key

Part #	Description	Reqd.	Years	Price
D-117	Hinge to Door Post Hardware. Screws and square nuts to fasten three hinges to one door.	1	1926-27	2.95 set
D-120	Door Latch Assembly. Bent arm type. Right rear only. Open Car Only. USA.	1	1917-25	28.50 ea.
D-122	Door Latch Assembly. Bent arm type. Right front & Left rear. Open Car. USA.	1	1917-25	28.50 ea.
D-123	Dovetails. Male. 4 hole type. Chrome plated. Closed Car & Truck.	1	1924-27	4.95 pr.
D-123-A	Dovetail, Female. 4 hole type. Stamped steel w/mtg. hardware. Fits on door post. Closed Car.	2	1924-27	9.95 ea.
D-123-B	Door Striker Plate with Mounting Hardware. Fits on door post. Closed Car & Truck. (2 pc. set)	2	1925-27	9.95 ea.
D-124	Door Latch Assy. USA. Bent arm style. Left side, front or rear. Open Car only.	1	1926-27	28.50 ea.
D-126	Door Latch Assy. USA. Bent arm style. Right side, front or rear. Open Car only.	1	1926-27	28.50 ea.
D-127	Door Latch. Right Hand. Closed Cars and 1928-29 CC Pickup.	1	1926-27	119.95 ea.
D-128	Door Latch. Left Hand. Closed Cars and 1928-29 CC Pickup.	1	1926-27	119.95 ea.
D-132	Deck Lid Key. (Must be modified to fit 1923-25).	1	1923-27	8.95 ea.
D-136	Deck Lid Lock Assembly.	1	1926-27	24.95 ea.
D-138	Deck Lid Hinges. Roadster only.	1	1926-27	29.95 pr.
D-267	Sun Visor Framework. Fits Coupe & Tudor Sedan. These are sold less covering. See #D-268 Cover Kit.	1	1926-27	98.95 ea.
D-268	Sun Visor Cover Kit. Cobra long grain material matches the top material for a trim appearance of the visor. Closed Coupe & Tudor.	1	1926-27	29.95 kit
D-307	Door Bottom Patch Panels. with Bead. Coupe & Tudor Sedan.	1	1926-27	78.95 pr.
D-308	Door Bottom Inner Patch Panels. Coupe & Tudor Sedan.	1	1926-27	44.95 pr.



D-120



6432

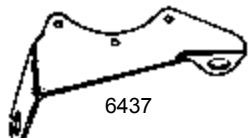

6437



6437-DX



6440-B



6440-A

6440-BR



6440-E

## Horn, Etc.

6432	Horn Assembly w/ Bracket. Negative ground only. 6 volt.	1	1926-27	259.95 ea.
6437	Bracket for Battery Horn. Stamped steel.	1	1917-25	16.95 ea.
6437-DX	Bracket for Battery Horn. Stamped steel.	1	1926-27	10.95 ea.
6440-A	Exhaust Whistle Valve. This unit connects whistle to your exhaust pipe. 'T' is 1-1/2" dia.	1	1909-27	89.95 ea.
6440-B	Exhaust Valve Foot Pedal. Provides easy foot operation of whistle valve.	1	1909-27	48.95 ea.
6440-BR	Brass Exhaust Whistle. This 4 tube <i>Aeromore</i> whistle has authentic brass tubes sounds just like the midnight mail train from Grandpa's day. Great parade fun. Requires 6440-A & 6440-B to work on your 'T'.	1	249.95 ea.	
6440-E	Spark Plug Whistle Kit. A popular and effective warning device using the spark plug explosion to produce a sharp whistle sound. Kit includes whistle, plug adapter, kick pedal & cable.	1	1909-27	149.95 kit

# Model T Parts

## Horn, Etc.

Part #	Description	Reqd.	Years	Price
6440-H	<b>Hollywood Wolf Whistle.</b> Die cast alloy vacuum whistle w/ fittings & instructions. Operates on manifold vacuum.	1	1909-27	49.95 ea.
8028-X	Horn Button Assembly w/ Mounting Clamp.	1	1915-27	34.95 ea.
H-25	Horn Bulb. Black with brass ferrule. 5/8" I.D. x 5-1/4" long x 3-1/4" wide.	1	All	18.95 ea.
H-26	Horn Bulb. Black with brass ferrule. 5/8" I.D. x 6-1/2" long x 4-1/2" wide.	1	All	22.95 ea.
H-27	Mounting Bracket for Brass Horns. For horn bulb & flexible tubing. H-29 fits this threaded end.	1	1910-16	12.95 ea.
H-28	Horn Reed Holder. Brass. Solders to horn. Threaded inside for reed. Threaded outside for H-29.	1	All	7.50 ea.
H-29	Threaded Reed Cover & Bulb Connector. Brass. Screws to H-28. Horn bulb slips over end. Also used with H-27 bracket.	1	All	10.95 ea.
H-30	Brass Reed for Bulb Horn. Threaded to fit H-28.	1	All	12.50 ea.
7824-C	Windshield Glass Clamp. For Open Car.	4	1923-25	4.25 ea.
7824-D	Windshield Glass Clamp. For Open Car.	4	1926-27	4.25 ea.
7831-BRX	Curtain to Windshield Hooks. (Set of 4)	1	1915-27	1.95 set
7853-X	Rearview Mirror. Open Car. Authentic style mounts to top center of windshield frame. Just paint and install.	1	1916-27	46.50 ea.
8320-BX	Door Lever Pads. Closed Car.	1	1922-27	3.50 pr.
18257-X	Windshield Wiper. Hand operated. Chrome plated. Open Car.	1	1910-29	22.95 ea.
18258-BL	Wiper Blade Only for Above. Open Car.	1	1910-29	5.95 ea.
18258-CL	Hand Wiper Clamp Set. Holds #18257-X to any windshield frame without drilling any holes.	1	1910-29	6.95 set



6440-H

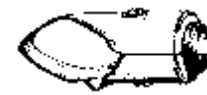

8028-X



H-25/26



7824-C



H-30



8320-BX



18258-CL

## Open & Closed Car Top Parts

The Top Assemblies below include Bows, Hold Down Clamps, Thumb Screws, Top Prop Nuts, Top Sockets & Rivets. Less Fabric.

The Top Covering Kits listed are available in **Colonial** or **Cobra Short Grain** vinyl for open cars and **Long Grain** vinyl for closed vehicles. **Black only.** Kit comes complete with instructions, top pads, welting, tips, tacks and straps. Top pad cover is the same color on both sides. Rear plastic window sewn in proper position. Kits do not include any fasteners to attach tops to body of car. We can provide hardware kits in most cases—advise us of your specific need.

**Note: Special Order Items must be prepaid and are non returnable.**

7940-RX	Top Assembly. Bows, hold-down clamps, prop nuts, thumb screws, top bow sockets & rivets; less fabric. Roadster & Roadster Pickup. <b>Specify Year.</b>	1917-27	call for price
7940-TX	Top Assembly. Bows, hold-down clamps, prop nuts, thumb screws, top bow sockets & rivets less fabric. Touring. <b>Specify Year.</b>	1917-27	call for price

# Model T Parts

Part #	Description	Reqd. Years	Price
<b>Open &amp; Closed Car Top Parts</b>			
7942-RTK	Top Covering Kit w/Instructions. Black. Includes top pads, bow covers, cross straps, rear curtain with plastic window, welting trim, Tips & Tacks. Roadster. <i>Specify Year &amp; 'Colonial or Cobra' Grain Material.</i>	1917-27	call for price
7942-TTK	Top Covering Kit w/ Instructions. Black. Includes top pads, bow cover, cross straps, rear curtain with plastic window, welting trim, tips & tacks. Touring. <i>Specify Year and 'Colonial or Cobra' Grain Material.</i>	1917-27	call for price
7943-CS	Top Material Hardware Set. These "common sense" fasteners include body, top iron & windshield fastner harware. Nickel plated. <i>Specify year &amp; body style.</i>	1916-25	call for price
7945-LDR	Top Material Hardware Set. (32 pcs.) These "lift the dot" fasteners include body, top iron & windshield fastener hardware. Nickel plated. Roadster.	1926-27	call for price
7945-LDT	Top Material Hardware Set. (42 pcs.) These "lift the dot" fastners include body, top iron & windshield fastner hardware. Nickel plated. Touring.	1926-27	call for price
7948-CTK	Top Covering Kit. Complete w/ instructions. Includes black long grain top material, foam padding, hide'um, tacks & sealant. Coupe only.	1915-27	110.00 kit
7950-STK	Top Covering Kit. Complete w/ instructions. Includes black long grain top material, foam padding, hide'um, tacks & sealant. Tudor & Fordor Sedan.	1922-27	132.50 kit

## Model T Accessories

T-1	'T' Style Sidelights with Clear Glass Lens. Cast aluminum. Paint black for authentic look. Non-functional.	1	All	79.95 pr.
T-2	Top Prop Studs. Holds main top bow to body. 15/16" shoulder. Roadster.	1	1925-27	9.95 pr.
T-2-BR	Top Prop Nut. Polished brass. 1-1/2" dia. 7/16" Std. thread.	2	1912 & up	7.95 ea.
T-2-L	Top Prop Studs. Holds main top bow to body. 1-5/16" shoulder. Touring.	1	1925-27	9.95 pr.
T-2-N	Top Prop Stud Nut. Fits T-2. 1-1/2" dia. 7/16" thread. Square nut. Stainless steel.	2	1925-27	8.50 ea.
T-3-A	Top Bow Saddles. 5/8" hole. USA.	1	1913-22	17.95 ea.
T-3-B	Top Bow Saddles. 1/2" hole. USA.	1	1923-29	17.95 pr.
T-4-B	Top Saddle Leather Pads & Straps.	1	1913-29	23.95 pr.
T-5-A	Top Saddle Rods. 5/8" dia. L shape for Roadsters. Overall length 7-5/8".	1	1909-22	15.95 pr.
T-5-AT	Top Saddle Rods. 5/8" dia. L shape for Touring Cars. Overall length 8-7/8".	1	1909-22	15.95 pr.
T-5-B	Top Saddle Rods. 1/2" dia.	1	1923-27	14.95 pr.
T-6	Front License Plate Bracket. Die stamped.	1	1909-20	3.95 pr.
T-7	Front License Plate Bracket. Powder coated.	1	1920-27	4.50 ea.
T-8	Crank Holder & Strap. Black leather.	1	1909-27	11.95 ea.

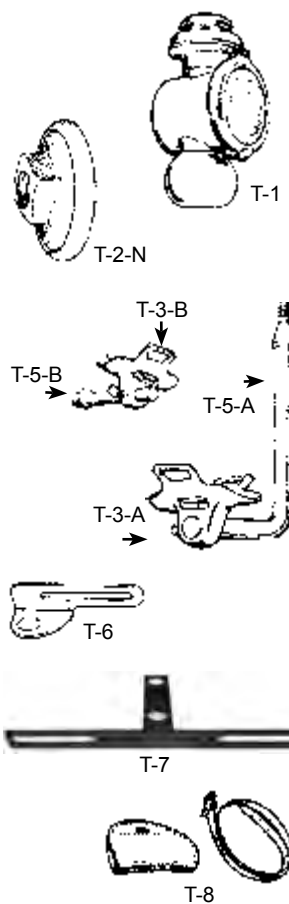

# Model T Parts

Part #	Description	Reqd. Years	Price	
<b>Model T Accessories</b>				
T-9	Transmission Band Changer. Easy extra hand.	1	1909-27	11.95 ea.
T-11	Oil Check Rod. The only way to check oil.	1	1909-27	4.95 ea.
T-12-B	Flag Holder Set. Complete with 5 American Flags & round adjustable clamp. Brass plated.	1	1909-16	31.95 set
T-12-C	Flag Holder Set. Complete with 5 American Flags & round adjustable clamp. Chrome.	1	1917-25	31.95 set
T-13-B	Dogbone Radiator Cap. Brass. Drilled for motometer.	1	1909-16	28.95 ea.
T-13-C	Dogbone Radiator Cap. Chrome plated brass. Drilled for motometer.	1	1916-27	24.95 ea.
T-14-B	Winged Radiator Cap. Brass. Drilled for motometer. Long wings.	1	1909-16	26.95 ea.
T-14-C	Winged Radiator Cap. Chrome. Drilled for motometer. Long wings.	1	1916-27	26.95 ea.
T-14-CS	Winged Radiator Cap. Chrome. Short wings.	1	1916-27	26.95 ea.
T-14-MB	Brass Motometer. Wreath rim. Ford face.	1	1909-16	49.95 ea.
T-14-MC	Chrome Motometer. Wreath rim. Ford face.	1	1917-27	49.95 ea.
T-15-A	Outside Oil Line with Adapter.	1	1909-25	31.95 ea.
T-15-B	Outside Oil Line.	1	1926-27	26.95 ea.
T-20-B	Ford Script. Polished die cut brass. 7-1/2" x 3-1/4".	1	All	15.95 ea.
T-20-C	Ford Script. Chromed die cut brass. 7-1/2" x 3-1/4".	1	All	19.95 ea.
T-21	Top Bow Side Strap Set. Black leather straps w/ brass pins. Correct 4" length. (2 per set)	1	1909-16	9.75 set
T-24-RK	Tire Pump Repair Kit. 17 peices except base & metal pump body. Accurately duplicated to fit all T' tire pumps with stamped steel or cast iron base. Wood handle, hose w/clamp, leather diaphragm, top cap, spring, etc.	1	1922-27	22.95 kit
T-26	Round Hind View Mirror. Brass.	1	1909-15	42.50 ea.
T-26-C	Round Hind View Mirror. Chromed.	1	1916-27	42.50 ea.
T-29	Dash to Windshield Brackets. Stamped in solid brass and polished to perfection. (4 pc. set)	1	1909-11	37.50 set
T-29-DB	Dash Brackets for Wood Dash. (5 pcs.) Solid brass. Highly polished. USA.	1	1909-11	22.50 set
T-30	Windshield Rubber Set. Open Car.	1	1915-22	7.95 set
T-31	Windshield Rubber Set. Open Car.	1	1923-25	7.95 set
T-31-A	Windshield Rubber Set. Open Car.	1	1926-27	7.95 set
T-32	Cowl Vent Door Gasket.	1	1926-27	2.50 ea.
T-33	Cowl Seal Rubber. Between windshield frame bottom & Open Car body.	1	1915-25	2.95 ea.
T-33-A	Cowl Seal Rubber. Between windshield frame bottom & Open Car body.	1	1926-27	2.95 ea.
T-34	Speedometer Cable Housing. Polished brass. 60" x 3/4" x 20 fine. Fits Stewart.	1	All	75.00 ea.
T-35	Speedometer Cable Housing. Polished brass. 60" x 7/8" x 18 fine. Fits Jones.	1	All	75.00 ea.





# Model T Parts

Part #	Description	Reqd.	Years	Price
<b>Model T Accessories</b>				
T-36	Speedometer Cable Housing. Polished brass. 60" x 7/8" x 18 coarse. Fits Ford. battery life. Not a replica.	1	All	75.00 ea.
T-40	Side Curtain Rods. Roadster & Roadster PU. (Set of 2) (Order 2 sets for Touring)	1	1926-27	9.95 set
T-45	Transmission Oil Strainer. Fits under transmission cover door. Magnet and 2 #3379-B gaskets included.	1	1911-27	29.95 ea.
T-47	Tire Cover. Script. Black vinyl. Fits 30 x 3 & 30 x 3 1/2 tire.	1	1909-24	37.95 ea.
T-47-T	Tire Cover. Script. Tan vinyl. Fits 30 x 3 & 30 x 3-1/2 tire.	1	1909-24	34.95 ea.
T-48	Tire Cover. Script. Black vinyl. Fits 21" tire. Wood or wire wheel.	1	1924-27	37.95 ea.
T-48-T	Tire Cover. Script. Tan vinyl. Fits 21" tire. Wood or wire wheel.	1	1924-27	34.95 ea.
T-51	Crankshaft Counterweights. (4 pc. set) Duplicate of Dunn Style. Ductile provides added strength.	1	1909-27	99.95 set
T-56	Bumper Face Bars. Stainless steel. Front or rear. (2 Bars)	1	1925-27	262.50 set
T-57	Front Bumper Mounting Bracket Set with Mounting Kit & Instructions.	1	1926-27	98.50 set
T-58	Bumper Clamp. Large outer with bolt. Painted black.	2	1925-27	12.95 ea.
T-60	Bumper Clamp. Large outer w/ bolt. Chromed.	2	1925-27	14.95 ea.
T-62	Bumper Clamp Backing Plate. Holds outer clamps to face bars. Steel painted black.	2	1925-27	5.25 ea.
T-64	Round Center Bumper Clamp w/ Backing Plate. With "Ford Made In U.S.A." as original.	1	1925-27	9.95 ea.

## Model T Trim Screws

First Grade Nuts, Bolts and Trim Screws for your Model 'T' interior. These are nickel plated and as close to the original as can be found.

TT-1	Roadster & Touring. (30 pcs.)	1	1917-22	4.00 set
TT-2	Coupe. (116 pcs.)	1	1919-22	13.95 set
TT-3	Center Door. (148 pcs.)	1	1917-22	17.95 set
TT-4	Roadster & Touring. (28 pcs.)	1	1923-25	3.00 set
TT-5	Coupe. (106 pcs.)	1	1923-25	14.95 set
TT-6	Fordor Sedan. (192 pcs.)	1	1923-25	22.95 set
TT-7	Roadster & Touring. (22 pcs.)	1	1926-27	2.95 set
TT-8	Coupe. (99 pcs.)	1	1926-27	13.95 set
TT-9	Tudor Sedan. (52 pcs.)	1	1926-27	7.95 set
TT-10	Fordor sedan. (200 pcs.)	1	1926-27	22.95 set
TT-11	Model T Cotter Pin Set. (97 pcs.)	1	1909-27	5.95 set

## Data Plates

P-1 thru P-6 are duplicates of the patent plate applied at the factory during production

P-1	Patent Plate w/Rivets. Brass.		1909-Mid '11	5.95 ea.
P-2	Patent Plate w/Rivets. Brass.		Late '11-Early '12	5.95 ea.



T-45



T-48

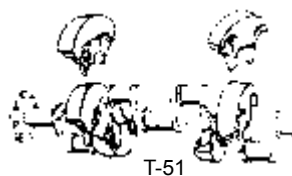

T-51



T-60



P-4



P-5



P-6

# Model T Parts

Part #	Description	Reqd.	Years	Price
<b>Data Plates</b>				
P-3	Patent Plate w/Rivets. Brass. Large plate.		Late 1912	6.95 ea.
P-4	Patent Plate w/Rivets. Brass.		1917-18	5.95 ea.
P-5	Patent Plate.		1919-25	1.50 ea.
P-6	Patent Plate.		1926-27	1.50 ea.
P-7	K.W. Switch Plate w/ Rivets for Coil Box.		1911-14	11.50 ea.
P-9	Radiator Patent & Number Plate. Brass.		1909-16	26.95 ea.



P-7

## Model TT Truck Parts

TT-1005	Rear Axle Housing Cap Gasket. Used on the worm drive differential cap.		1918-27	2.25 ea.
TT-1008-S	Worm Drive Axle Gasket Set. Rear end gaskets for worm drive TT truck. (4 pc. set)		1918-27	16.95 set
TT-1017	Rear Axle Steel End Caps with Felts & Steel Washers (6 pc. set).	1	1918-27	39.95 set
TT-1019	Axle Shaft Outer Roller Bearing. Fits TT-1020.	2	1918-27	49.95 ea.
TT-1020	Axle Shaft Rear Bearing Sleeve. Fits right or left side.	2	1918-27	19.95 ea.
TT-1021	Axle Shaft Bearing Felt.	2	1918-27	1.95 ea.
TT-1026	Rear Axle Inner Grease Seals. Steel with Neoprene inner seal.	1	1918-27	49.95 pr.
TT-1028-B	Differential Gear Case. Right or left.	2	1923-27	22.50 ea.
TT-1037	Torque Tube Gasket. Fits the torque tube flange on the worm drive rear end.		1919-29	3.00 ea.
TT-1039	Drive Shaft Felt.	1	1918-27	1.95 ea.
TT-1046	Worm Gear Roller Bearing.	2	1918-27	64.95 ea.
TT-1057	Brake Lining. Woven type with rivets. (4 pc. set)	1	1918-27	79.95 set
TT-1062	Brake Expander Lever.	2	1918-27	9.50 ea.
TT-1064	Brake Expander Adjusting Collar.	2	1918-27	7.50 ea.

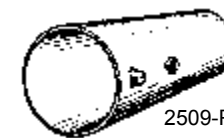

2509-P

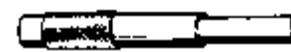

2718-T



3044-DR



3053



3061-W



3416-W

## Model T Tools

2505-WP	Wheel Puller. Screw-on type. Our superior design will not strip the threads on your axle. Made in Ohio (Not useable on T steering)	1	1912-48	2.95 ea.
2509-P	Rear Axle Sleeve Puller. Passenger Car only.	1	1909-27	14.95 ea.
2718-T	Spindle Arm Bushing Driver. Also for front & rear spring perch bushings. Case hardened.	1	1909-27	7.95 ea.
3044-DR	Camshaft Rear Bushing Driver.	1	1909-27	7.95 ea.
3052-G	Valve Setting Gauge. This stainless gauge sets valve clearance by piston travel. Instructions incl.	1	1909-27	14.95 ea.
3052-R	Valve Guide Reamer. Reams worn guides to .3275. USA.	1	1909-27	56.95 ea.
3053	Valve Spring Compressor Tool. Quality tested for proper fit. Instructions included.	1	1909-27	29.95 ea.
3061-W	Exhaust Pack Nut Wrench. Ductile iron. A much needed tool to tighten or remove the exhaust pack nut. USA.	1	1909-27	28.95 ea.
3170	Timer Calibrating Gauge. Authentic tool for tiger timers.	1	1911-27	1.25 ea.
3314-D	Triple Gear Bushing Driver. Hardened steel.	1	1911-27	7.95 ea.

# Model T Parts

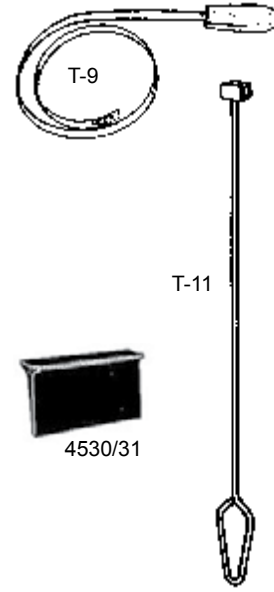

Part #	Description	Reqd.	Years	Price
3416-W	<b>Model T Tools</b> Transmission Band Adjusting Wrench & Holder. Chained together to prevent loss.	1	1909-27	18.95 ea.
T-9	Transmission Band Changer. Easy extra hand.	1	1909-27	9.95 ea.
T-11	Oil Check Rod. The only way to check your oil.	1	1909-27	4.95 ea.

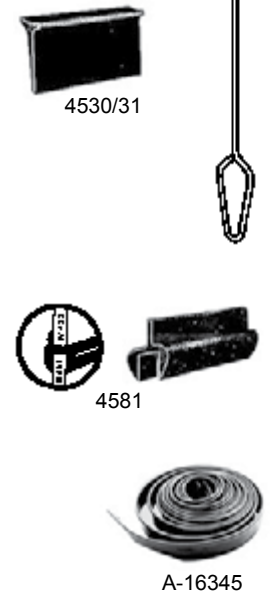

Part #	Description	Reqd.	Years	Price
4530	<b>Model T Rubber</b> T Rubber for Open & Closed Car & Truck Windshield Weatherstrip Groove. Concave head. 3/4" - 9/32" head.			0.75/ft.
4531	T Rubber for Open & Closed Car & Truck Windshield Weatherstrip Groove. Concave head. 1" - 9/32" head.			0.75/ft.
4581	Windshield Weatherstrip. 'H' style for 1/4 glass.			0.75/ft.
A-16345	Black Fender Welt. 1-1/2" wide. (3/16" bead) Bright, smooth finish bead. 25' roll.			7.50/roll

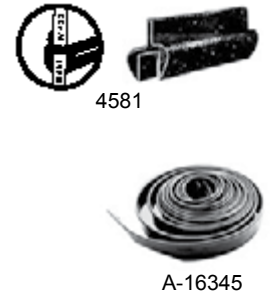

Part #	Description	Reqd.	Years	Price
T-Hat	Blue Ford T Baseball Hat.			7.95 ea.
T-LUBE	T Lubrication Chart			7.50 ea.
T-TS	Model T Trouble-shooting Poster. An authoritative chart outling the common derangements that interfere with proper action of engine & auxilliary systems.		1909-27	7.95 ea.
T-WP	Model T Parts Poster. This poster is a copy of an original Parts Department Wall Poster showing Passenger and TT Truck parts. 22" X 28"			4.95 ea.

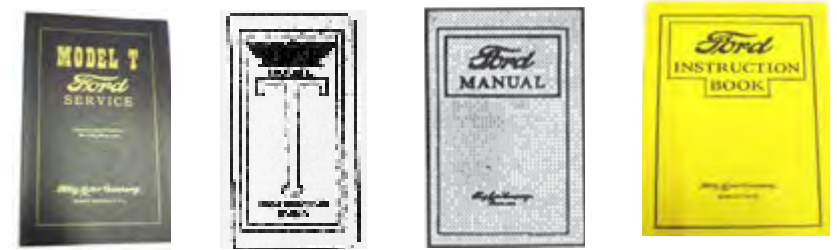

Part #	Description	Reqd.	Years	Price
TB-1	<b>Model T Books</b> <b>Model T Service &amp; Repair Manual 1909-27</b> The "Bible" for the Model T man. Original book by company for all Model T years. 320 pages, 577 illustration.			32.95 ea.
TB-2	<b>Model T Instruction Book 1909-15</b> This small booklet was supplied for the owner's use. 48 pages, 18 illustrations.			11.95 ea.
TB-3	<b>Ford Manual 1915-25</b> The first known attempt to guide the mechanic in repair by questions & answers. 64 pages, 26 illustrations.			11.95 ea.
TB-4	<b>Instruction Book 1926-27</b> Although dated as 1926-27, this book notes the changes of the Mid 1920's.			11.95 ea.
TB-5	<b>Parts List 1909-15</b> The first book for the Model T engine & chassis. 62 pages.			8.95 ea.



# Model T Parts

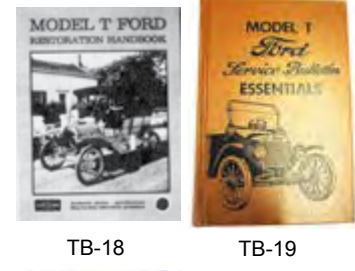
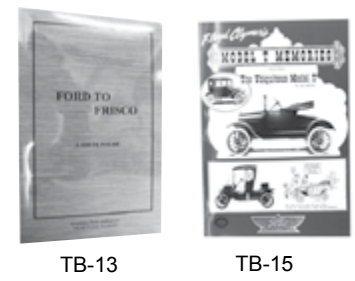
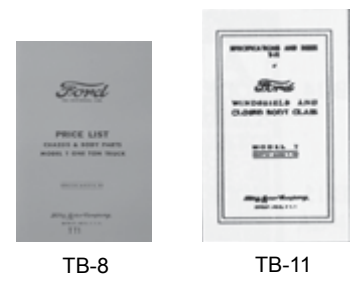

Part #	Description	Reqd.	Years	Price
TB-6	<b>Model T Parts and Accessories 1909-21</b> Complete parts list for the Model T Ford. 39 pages, 14 ill.			6.95 ea.
TB-6A	<b>Ford Price List of Parts.</b> Exact reprint of the 1923 Ford chassis parts list. Issued by Ford to identify the NEW style as well as the older style Model T.			5.95 ea.
TB-7	<b>Ford Price List of Parts 1922-27</b> List of engine & chassis parts including Ruckstell axle.			11.95 ea.
TB-8	<b>Price List-Chassis &amp; Body Parts 1923</b> 1 Ton TT Truck. 16 pages.			4.95 ea.
TB-9	<b>Ford Price List of Body Parts 1923</b> Excellent illustrations of Model T body construction. 39 pages.			8.95 ea.
TB-10	<b>Ford Price List of Body Parts 1915-27</b> This is the most complete of Model T body parts' lists including the T pickup & truck.. 93 pages, 37 illustrations.			11.95 ea.
TB-11	<b>Windshield &amp; Glass Specifications 1915-27</b> Deminsions & diagrams for Truck and Passenger Car. 14 pages, 47 illustrations.			6.95 ea.
TB-13	<b>Ford to Frisco</b> Written by J. Smith Walsh, 41 pages, 1909-27.			10.95 ea.
TB-15	<b>Model T Memories 1909-27</b> Relates experiences one might have with the Model T. Data and information. 112 pages, 59 photos.			18.95 ea.
TB-16	<b>Floyd Clymer's Historical Motor Scrapbook</b> Photos & early ads about the Model T. 229 Pages, 250 photos.			16.95 ea.
TB-17	<b>Model T Ford Owner's Supply Book 1909-27</b> Information on Model T accessories & replacement parts. 128 pages, 1,000 illustrations.			19.95 ea.
TB-18	<b>Model T Ford Restoration Handbook</b> The first book to get into Model T rebuilding. Written by Les Henry, a former Ford curator. 181 pages, 156 illustrations.			34.95 ea.
TB-19	<b>Model T Service Bulletins 1909-27</b> A reprint of original Model T service bulletins as issued by Ford. 520 pages, 900 illustrations.			34.95 ea.
TB-20	<b>Model T Speed Secrets: The Fast Ford Handbook 1909-27</b> Discover the fast Ford during the trial and errors of early day auto racing. 192 pages, 175 illustrations.			19.95 ea.
TB-21	<b>The Model T Ford Owner 1909-27</b> Articles covering the performance, operation and technical data. 528 pages, 800 illustrations. Hardbound.			32.95 ea.
TB-22	<b>Model T Ford in Speed &amp; Sport 1909-27</b> 224 pages, 300 illustrations.			18.95 ea.
TB-23	<b>Model T Axles, Front &amp; Rear 1909-27</b> Great detail in this 30 page restoration manual for 'T' front or rear axles. We offer all 7 titles from <i>Model T Ford Club of America</i> . Our TB-23 thru TB-23-F.			12.00 ea.
TB-23-A	<b>Model T Engine Manual 1909-27</b> Repair & restoration of the 'T' motor is covered in this 24 page manual from the <i>MTFCA</i> .			12.00 ea.
TB-23-B	<b>Transmission Manual for Model T 1909-27</b> This <i>MTFCA</i> manual of 151 pages takes you step-by-step through the rebuilding of the transmission of the Model T.			12.00 ea.
TB-23-C	<b>Model T Ford Books</b> <b>The Model T Carburetor 1909-27</b>			12.00 ea.

# Model T Parts

Part #	Description	Reqd. Years	Price
TB-23-D	This manual on the 'T' carburetor by the <i>MTFCA</i> is 48 pages, which covers all the carburetors types as found on our 'T's'. Great detail. <b>The Ruckstell Manual for Model T 1909-27</b> The complete Ruckstell R&R manual contains 35 pages of extensive details. Again the <i>MTFCA</i> brings to life an era of technical progress.		12.00 ea.
TB-23-E	<b>Electrical Manual, Model T 1919-27</b> <i>The Model T Ford Club of America</i> provides 48 pages of highly detailed information, including generator & starter rebuilding.		12.00 ea.
TB-23-F	<b>Speedometer Manual for Model T 1909-27</b> This 62 page manual covers models used through-out 'T' production. Well illustrated. <i>MTFCA</i> offers a look at this topic.		12.00 ea.
TB-24	<b>Model T Parts Identification Guide Vol. 1</b> Shows correct part for your Model T year. However not all part numbers listed. Covers early years properly. 61 pages.		17.95 ea.
TB-24-2	<b>Model T Parts Identification Guide Vol. 2</b> This second volume has over 260 illustrations to aid you in identifying genuine Model T parts.		17.95 ea.
TB-24-3	<b>Model T Parts Identification Guide Vol. 3</b> Over 300 illustrations and 52 pages to aid in identifying Model T parts.		22.95 ea.
TB-25	<b>Model T Parts &amp; Accessories 1909-26</b> Illustrated pocket size book shows what years will interchange.		6.95 ea.
TB-26	<b>Ford Sales Data Book 1926-27</b> This sales data book, used by salesmen, offers factory accessories for the improved Ford. 40 pages.		4.95 ea.



TB-23-C

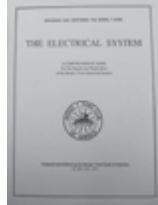

TB-23-E



TB-23-F



TB-24



TB-24-2



**We have many USED Model 'T' Parts... ask us. Call today and talk to a knowledgeable person, not a recording.**

# Model T Parts

**Ahoogah!**  
**Roadster Accessories Has Everything You Need!**

- AHOOGAH HORN.** Black, chrome bell, or all chrome. 6 or 12 volt. Repr. (Also Available: Tube Horns, Double & Triple Twist Horns!)
- WINDSHIELDS, POSTS, HARDWARE.** Brass, plain steel or chrome windshields. Polished or chrome posts.
- WINDSHIELD WIPER.** Black. (Also Available: Vacuum, Electric Wipers, Inside or Outside Mount).
- WOOD RIM STEERING WHEEL.** 10 1/2" and 12" inside diameter. Polished brass or chrome plated.
- WINDSHIELD HINGE.** For folding windshields, solid brass.
- TAIL LAMP AND LICENSE BRACKET.**
- ORIGINAL EQUIPMENT FLOOR MATS.** High quality heavy rubber, sharp design. Large borders fit all body styles. Front floor, rear touring.
- VINTAGE DOOR HANDLE, LATCH ASSEMBLIES & HINGES.** Chrome. Locking or non-locking.
- FRONT SPRING PERCH, SPRINGS, SHACKLES AND STEERING ARM.**
- HEADLIGHTS.** Chrome plated, sealed beam.
- HEADLIGHT POST.** Polished frame mount type.
- MOTO-METERS.** Exact reproduction, chrome or polished brass. Standard or deluxe.
- SIDE LIGHT BRACKET.** Several styles.
- AUTHENTIC VINTAGE REARVIEW.** Inside or outside mount for closed or open cars. Black, chrome or brass.

**See our many new & used parts on [www.gaslightauto.com](http://www.gaslightauto.com) and like us on facebook.**